

## Harmonic Mitigating Transformers

### Application Guide Class 7400

#### ABOUT THIS DOCUMENT

This document is a guide for applying Harmonic Mitigating Transformers (HMT). The Low Voltage Dry Type Distribution Transformer Product Support Group is also available as a resource. If the harmonic issue is severe, contact Square D for support. Square D's Power System Analysis group can provide a complete analysis of your electrical distribution system and make recommendations to match your specific application criteria.

#### INTRODUCTION

Harmonic Mitigating Transformers (HMT) accomplish harmonic mitigation (attenuation) (see "What are Harmonics?" on page 6) by providing good source impedance and through sine wave recombination. Sine wave recombination occurs within the transformer itself at the nodes, the connection points, of the windings. Sine wave recombination also occurs when the sine waves are phase shifted using multiple transformers. All of these methods may help reduce harmonics in electrical distribution systems.

While not intended as a complete technical analysis, this bulletin will highlight the appropriate application of HMTs. It is interesting to note that none of this is new technology. In variable frequency drive applications, harmonic mitigation has been accomplished with transformers for more than 50 years. Additional information regarding some of the theory of harmonic mitigation using transformers is included in the appendices.

#### INDUSTRY TRENDS

Harmonic mitigation is a topic of high interest among North American industry users and manufacturers. However, the European community has established guidelines to control the maximum level of harmonics that equipment can introduce onto a system. Computer and business equipment manufacturers, in response to the European Community guidelines, created power supplies that do not burden an electrical system with harmonics. It is likely that North America will soon follow the limited harmonic path.

#### STANDARDS

The standard for evaluating transformers serving non-linear loads is IEEE C57.110. This standard recognizes the effects of harmonic attenuation (reactive effect on harmonic levels) and harmonic diversity (cancellation effect of multiple non-linear loads). C57.110 is often ignored by some HMT vendors.

#### EXCEPTIONS

- IEEE Standard 1100-1992 (the Emerald Book) is not appropriate for evaluating transformer loading with non-linear loads. Any such references should be ignored.
- IEEE Standard 519-1992 is not intended for use within a facility. The standard sets the maximum harmonic voltage distortion level allowed at the point of common coupling between the utility and the customer. The point of 519 is to insure that one customer's power usage profile does not negatively impact another customer.

## PROPER APPLICATION OF THE TRANSFORMER METHOD OF HARMONIC MITIGATION

The installation of any Square D HMT transformer -- delta-wye, delta-zigzag, or wye-zigzag – provides an effective means of preventing triplen (3<sup>rd</sup>, 9<sup>th</sup>, 15<sup>th</sup>, etc.) harmonics from passing to the source side of the transformer. The standard conservative design practice of using delta-wye transformers automatically results in electrical distribution systems with some inherent harmonic mitigation (see Figure 1).

With a standard delta-wye transformer installed, the triplen harmonics are not trapped in the transformer, but nor do they pass through the transformer. The sine waves induced on the windings are recombined at the nodes of the delta into new sine wave shapes that do not contain triplen components (see “Combining Sine Wave Theory” on page 8).

The transformer’s reactance causes some attenuation of the harmonics and limits the crest factor allowed downstream (see “Source Impedance” on page 8).

**Figure 1: Standard Delta-wye Transformer Feeding a Computer Panel From a Distribution Panelboard.**

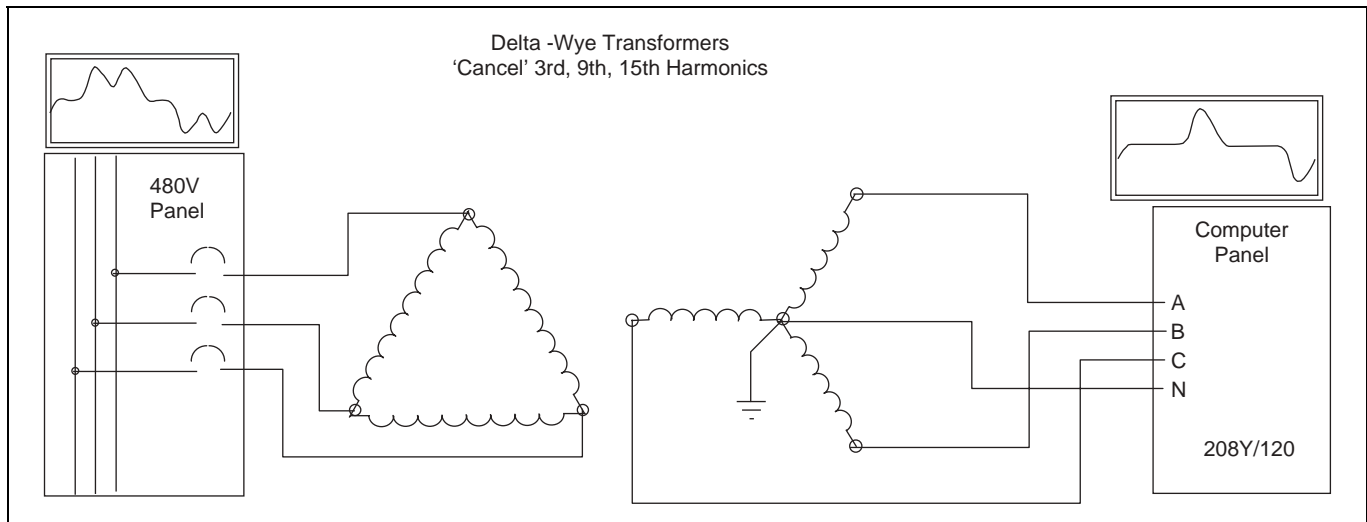

## APPLYING HMTS

Figure 2, illustrates a typical application of a 75kVA transformer feeding a 200 or 225 amp panelboard that serves computers. It is not the best way to apply an HMT to achieve the maximum harmonic mitigation possible. While the triplens will be attenuated, a single HMT with a zigzag secondary may not provide any significant additional benefit over a delta-wye HMT or a standard delta-wye transformer. However, if an HMT is being used to provide additional source impedance and/or phase shift from other non-linear loads elsewhere in the facility, some additional benefit may be achieved. The delta-wye is included in Square D's HMT product offering and is suitable to use in conjunction with delta-zigzag HMTs.

**Figure 2: A Single Computer Panel Being Fed Through One HMT From a Distribution Panelboard**

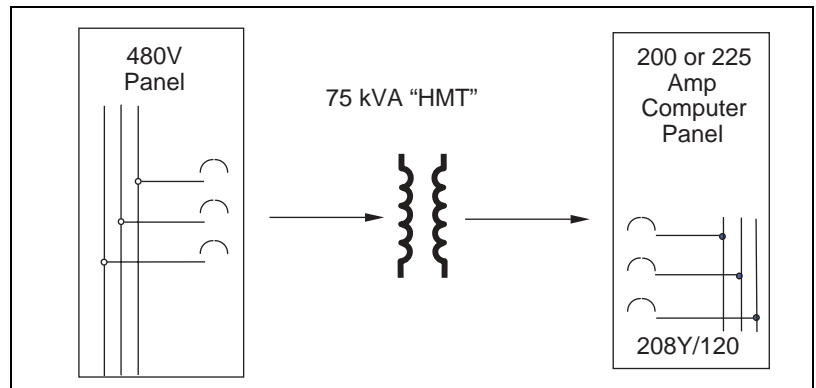

## HOW TO MAXIMIZE THE HARMONIC MITIGATION BENEFIT

To best utilize HMTs for the greatest attenuation of harmonics, it is necessary to balance the single-phase, line-to-neutral, non-linear load between two panels that are being fed by two different HMTs. One HMT should be a delta-zigzag, which has a 0° phase shift. And the second HMT should be either a delta-wye or a wye-zigzag, each of which has a 30° phase shift.

Using the two transformers will help attenuate the 5<sup>th</sup>, 7<sup>th</sup>, 17<sup>th</sup>, and 19<sup>th</sup> harmonics (see "Combining Sine Wave Theory" on page 8). Also, the more similar the load profile (operating as simultaneously as possible), the harmonic attenuation will be more effective.

Figure 3 shows the application of the two different HMTs, and is a much more beneficial application of the HMT theory than that shown in Diagram 2. The 75kVA transformer and single panel of Figure 2 has been replaced with two 45kVA transformers, each feeding a 100 or 125 amp panelboard, which in turn serve the computer loads.

*NOTE: See on page 8 where you'll note the wave shapes at each point in the electrical distribution system with the resultant supply side bus having only 11<sup>th</sup> & 13<sup>th</sup> harmonics as shown in Figure 16.*

Figure 3: Application of HMTs for Greater Harmonic Attenuation

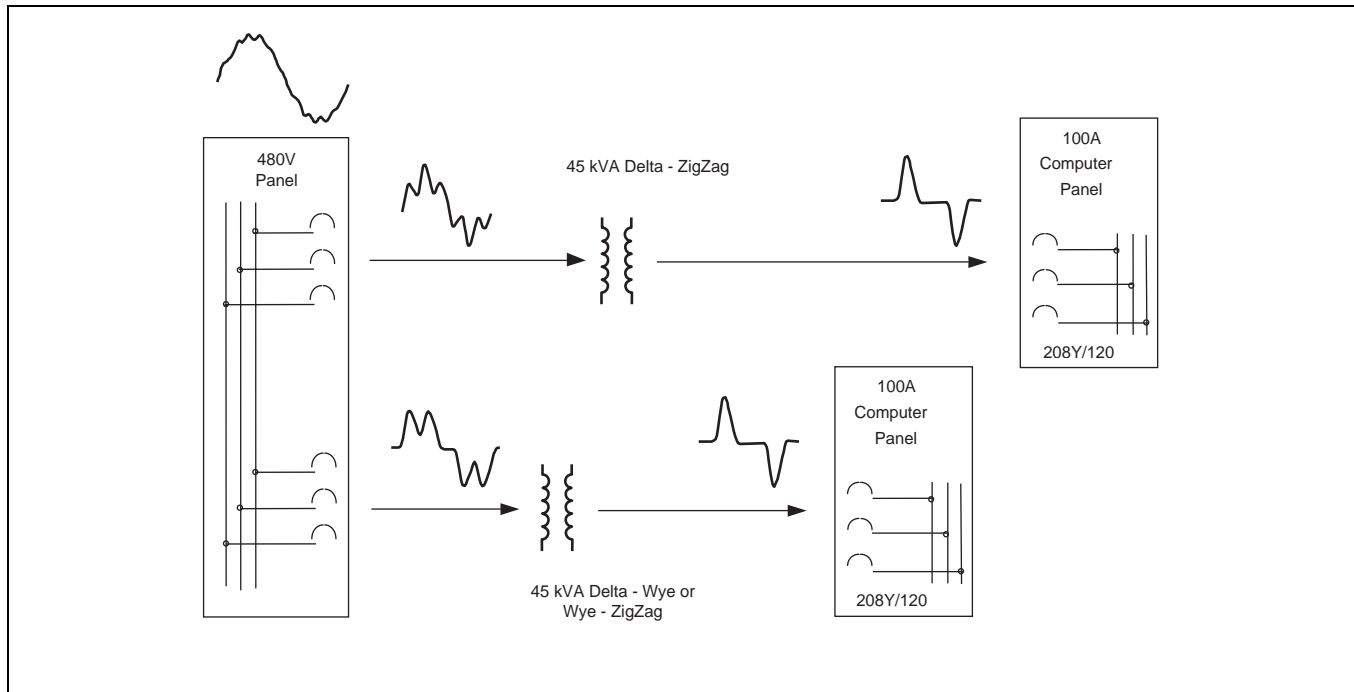

**HMT PLACEMENT AND IMPEDANCE**

In an ideal application, the two HMT transformers would have identical impedance values, would be located close to the common source bus, and have identical and simultaneous load harmonic profiles. However, this is rarely the case. The diversity of the harmonic profile of the 7<sup>th</sup> and higher order harmonics and the load dynamics both act to reduce the importance of the transformer impedance and placement (see “Harmonic Diversity” on page 13). Square D recommends the transformers be placed as close to the common source bus as possible.

**SINGLE-PHASE LINE-TO-NEUTRAL/GROUND IMPEDANCE**

<b>⚠ CAUTION</b>
<b>HAZARD OF ARC FLASH, BURN OR EXPLOSION</b>
When performing a coordination study and calculating available fault current, the single phase impedance of a transformer with a zig-zag secondary is less than the transformer’s positive/negative sequence impedance (indicated on the nameplate).
<b>Failure to calculate properly will result in serious injury and equipment damage</b>

One characteristic of a transformer with a zigzag secondary different from one with a wye or a delta secondary. In a delta-wye or a delta-delta transformer, the single-phase impedance is the same as the positive and negative sequence impedance, which is the impedance value provided on the nameplate of transformers 15kVA and larger.

The peak let-through current, or available fault current, is the same for either a line-to-line or a line-to-neutral/ground fault.

**Figure 4: Single-Phase Line-to-Neutral/Ground impedance of a Zigzag Winding**

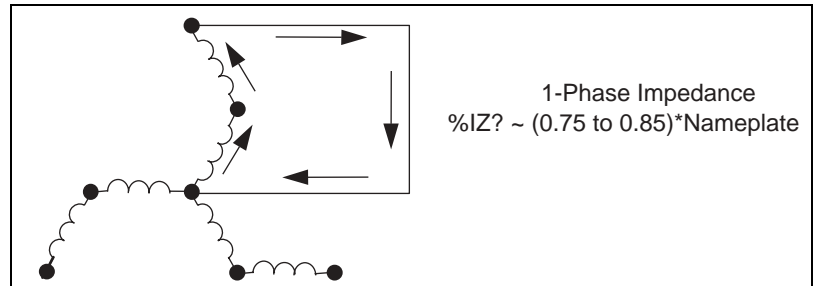

With a delta- or wye- zigzag transformer, the line-to-neutral/ground impedance is approximately 75% to 85% of the positive/negative sequence impedance. This results in a 17% to 33% greater available fault current in the event of a single-phase fault to neutral or ground (see Figure 4). This may necessitate higher rated over current protective devices. Since the only impedance value provided on the nameplate of the transformer is the positive/negative sequence impedance, it is recommended that the consultant use 133% of the calculated available fault current for the coordination study.

## APPENDICES

The following sections provide information on understanding harmonics, addressing harmonics with transformers, additional configurations and efficiencies.

### What are Harmonics?

In order to understand how an HMT may provide a benefit, it is first necessary to understand what harmonics are. In recent years the utilization of loads that draw decidedly non-sinusoidal current into our electrical systems has increased. The majority of such loads are three phase electronic motor drives in the industrial arena, and single-phase computer or related electronic loads in commercial settings. These loads share a common characteristic in that they both change AC to DC as a first step in their utilization of input power. In power supplies, as the rectifier only conducts in one direction as capacitors are charged once the voltage is above a certain magnitude, the current draw is said to be non-continuous, and causes current signatures that are not sine waves. These loads are commonly referred to as "non-linear".

**Figure 5: Single-phase Rectified Loads (example: electronic power supplies for computers, fax machines, and copiers)**

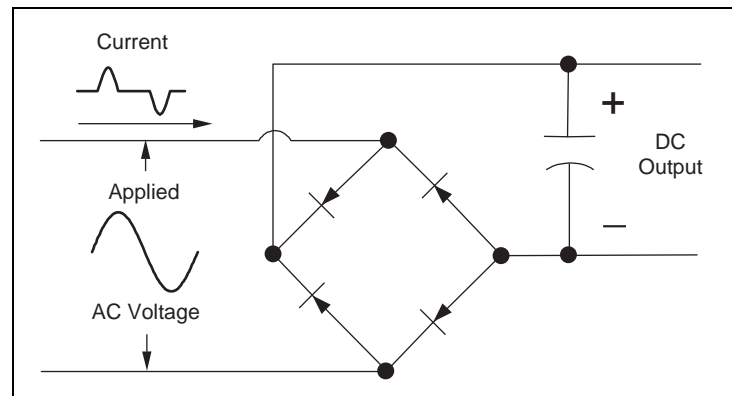

**Figure 6: Three-phase Rectified Loads (example: electronic (variable frequency) motor drives, furnace control, three phase lighting dimmers)**

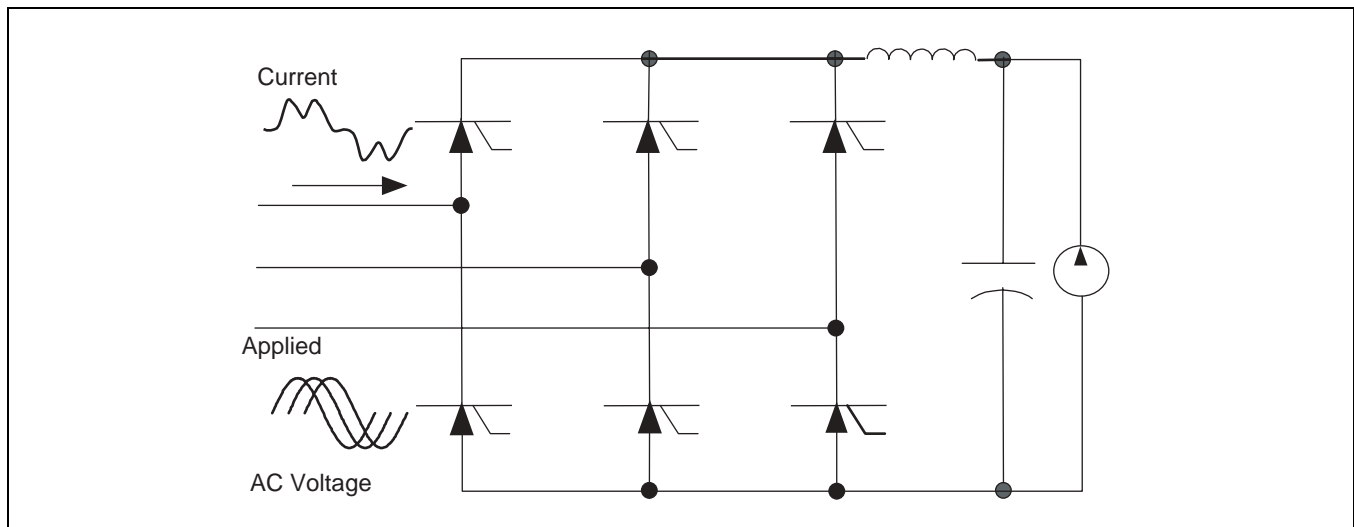

Distorted current (or voltage) is said to contain harmonic elements that can affect various kinds of upstream electrical devices.

## The Fourier Transformation

All periodic electrical power wave-shapes, whether current or voltage, can be mathematically “disassembled” into component sinusoidal elements called harmonics. The component harmonics are derived by a process called the Fourier Transformation. Each harmonic is at a multiple of the fundamental power frequency. In 60Hz systems, for example, the 3<sup>rd</sup> harmonic is at  $3 \times 60 = 180\text{Hz}$ , 5<sup>th</sup> at  $5 \times 60 = 300\text{Hz}$ , etc. At every instance of time, the sum of the instantaneous value of all component harmonics, including the fundamental determines a point on the power wave-form.

**Figure 7: Distorted Current Wave Form**

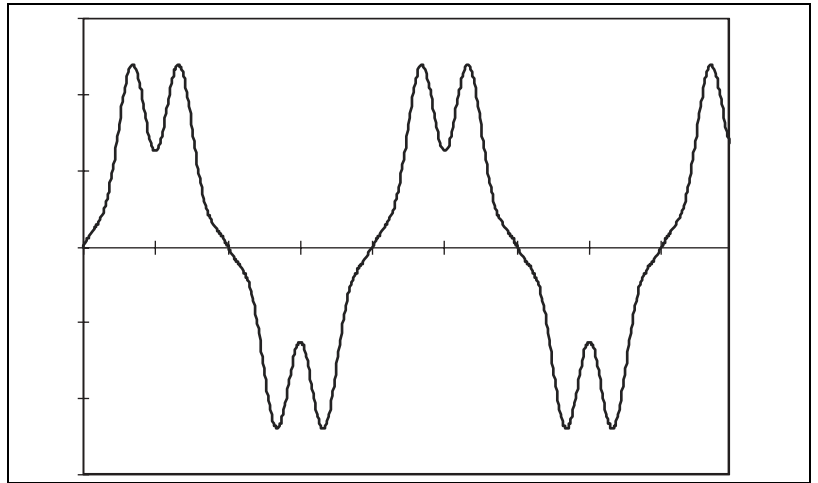

**Figure 8: Current Wave Form (shown as it's equivalent harmonic components)**

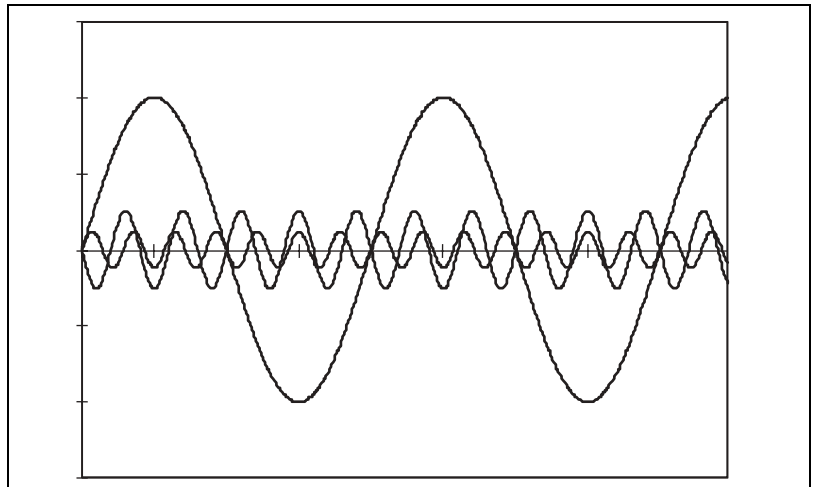

For the purpose of analyzing the affects non-linear loads have on transformers, it is important to note that we must remember the actual wave shape, and that harmonics are mathematical entities that allow us to define the effects of distorted power on components of the electrical system. This is key when addressing claims that triplen harmonics (multiples of 3 of the fundamental, the 3<sup>rd</sup>, 9<sup>th</sup>, 15<sup>th</sup>, etc. harmonic) circulate in the delta of a delta-wye.

---

**Methods of Addressing Harmonics with Transformers**

Transformers may be used to address harmonics generated by non-sinusoidal (non-linear) loads by providing good source impedance, combining sine waves within the transformer, and combining sine waves at the common bus feeding different transformers.

**Source Impedance**

Source impedance has the effect of attenuating the crest factor created by a non-linear load. Once the voltage rises to a specific point, the control circuitry in the power supply allows a capacitor to be charged. With low source impedance, the current drawn by the capacitor is high and the duration of the charging cycle is short. Higher impedance does not allow as much current to be drawn, and extends the time it takes to charge the capacitor. This is how the crest factor is reduced, as well as the harmonics. An example of how this has been done for years is the use of line reactors or drive isolation transformers that feed drives, and, more significantly, this is also done every time an isolation transformer is used!

**Combining Sine Waves**

Not only do transformers improve the source impedance for non-sinusoidal loads, but they also combine sine waves within the windings for additional harmonic attenuation. To take it one step further, two or more transformers of different phase angle shift(s) can be used to achieve further combination of sine waves providing for more harmonic mitigation. The phase shifts can be accomplished using standard NEMA wiring configurations or minor variations thereof. Either way, it is not new technology.

**Combining Sine Wave Theory**

The theory of combining sine waves is accomplished two ways.

- By using the inherent phase angle displacement of the electrical wave shapes within the transformer which are then combined at the nodes, or connection points, of the windings within the transformer.
- By combining the sine waves at the common bus feeding two transformers of different phase shift.

This bulletin will concentrate on single-phase, line-to-neutral, non-linear loads. Three phase non-linear loads have been successfully addressed for over 50 years by using line reactors, drive isolation transformers, or active filters.



Cancellation of the Triplens ( $3^{rd}$ ,  $9^{th}$ ,  $15^{th}$ ...)

“Cancellation” of the triplen harmonics ( $3^{rd}$ ,  $9^{th}$ ,  $15^{th}$ ...) can be achieved if a  $60^\circ$  phase shift is created between the two wave shapes, and then combined.

**Figure 9: Two Single-phase Non-linear Wave Shapes With a  $60^\circ$  Phase Angle Difference**

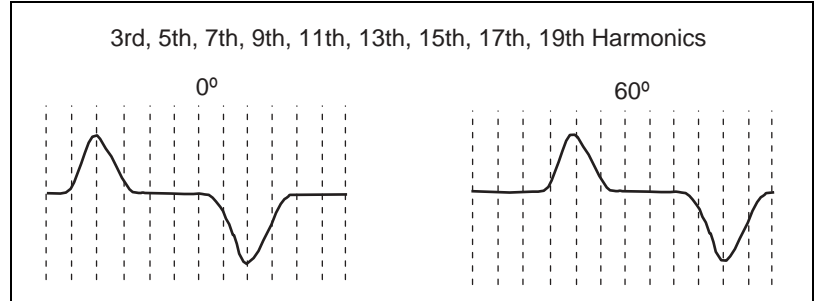

**Figure 10: The Combination of The (Figure 9) Wave Shapes**

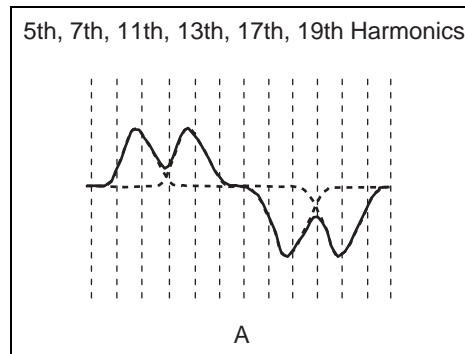

The resultant wave shape of Figure 10 will be referred to as wave shape “A” throughout this paper.

The triplen harmonics are no longer part of the wave shape. More importantly, none of the energy was removed from the wave shape. Rather, the sine waves were simply combined. This is one step where some mistakenly assume the triplen harmonics to be circulating in the delta winding of a delta-wye transformer.

The “A” is found on the line side of either a standard delta-wye or a wye-zigzag transformer that feeding single-phase, line-to-neutral non-linear loads.

**Figure 11: Delta-Wye/Wye-Zig-zag**

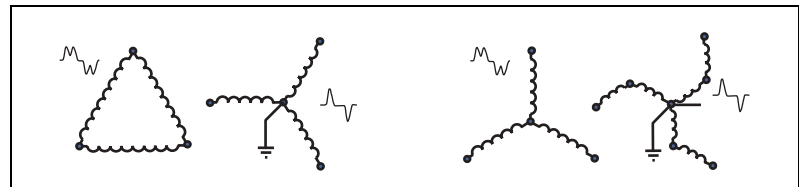

**Figure 12: Two “A” Wave Shapes With a 60° Phase Angle Difference**

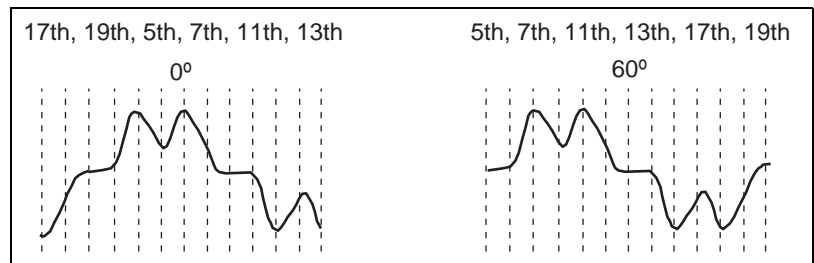

**Figure 13: The Combination of Two (Figure 12) “A” Wave Shapes.**

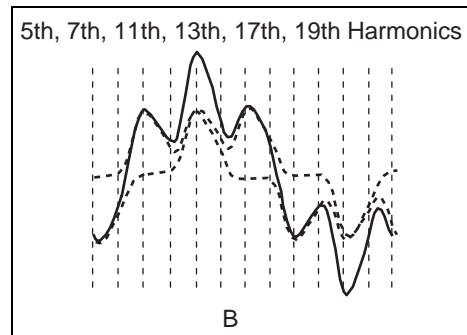

The Figure 13 combination is created with two “A” wave shapes and a 60° phase shift so the new “B” wave shape can be more easily understood. No harmonic cancellation takes place in the (“A”) + (“A”+60°) combination.

This applies to harmonic mitigation/attenuation via transformers in two ways.

- The “B” wave shape combination (remember, no triplen harmonics present) can be obtained through tiering of delta-wye transformers as is commonly done in many commercial and industrial facilities. The “B” wave shape is found on the source side of a delta-wye transformer that is feeding another delta-wye transformer downstream that is serving computers, fax machines, and other office equipment.
- The delta-zigzag transformer takes the single-phase, line-to-neutral non-linear single hump sine waves and combines them to get the “B” wave shape. Once again, no energy was removed from the wave shape. The sine waves are combined to yield a new sine wave in which the triplen harmonics are not present.

**Figure 14: Delta – Zigzag**

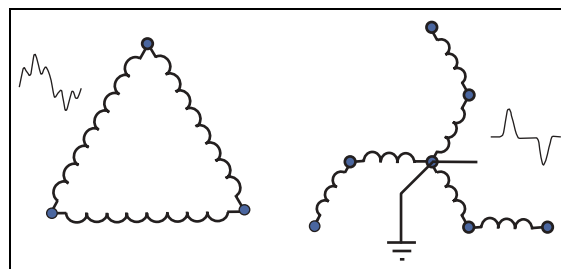

Cancellation of the Triplens (3<sup>rd</sup>, 9<sup>th</sup>, 15<sup>th</sup>...)

When a 30° phase shift is achieved between an “A” and a “B” wave shape (see Figure 15), and the two are combined (see Figure 16), “cancellation” of the 5<sup>th</sup>, 7<sup>th</sup>, 17<sup>th</sup>, and 19<sup>th</sup> occurs.

**Figure 15: “B” Wave Shape With No Phase Shift; “A” Wave Shape Phase Shifted By 30°**

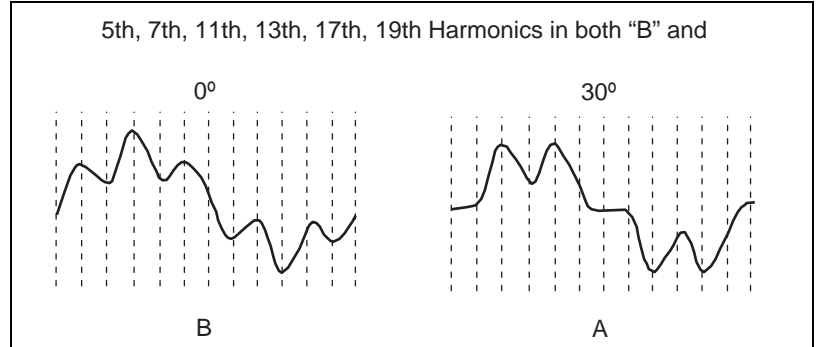

**Figure 16: The Combination of The “B” And 30° Phase Shifted “A” Wave Shapes.**

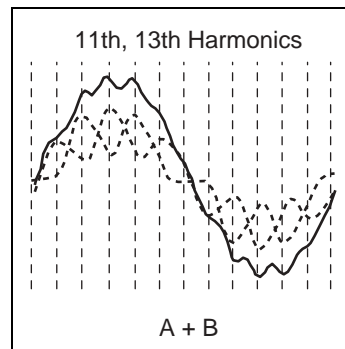

The “A” wave shape is phase shifted 30° and the “B” wave shape is not. The 30° phase shift of the “A” wave shape occurs with either the standard Delta-Wye transformer or a Wye-Zigzag transformer as noted in Figure 11. The “B” wave shape occurs with a Delta-Zigzag transformer (see Figure 14), which has no inherent phase shift (0°) between the primary and secondary. This can also occur within facilities with tiered delta-wye transformers.

One Step Further

Could additional transformer winding configurations and sine wave combinations theoretically eliminate all load harmonics on the supply side of the transformers? Theoretically, yes, though it is not at all realistic in real world applications. That will be discussed later in this paper. Theoretically, if two A+B wave shapes were combined with one of the wave shapes phase shifted by 15°, all of the harmonics could be “cancelled” (as shown in Diagram 17).

**Figure 17: Combination of Two “A+B” Wave Shapes With One Of The Two Phase Shifted By 15°**

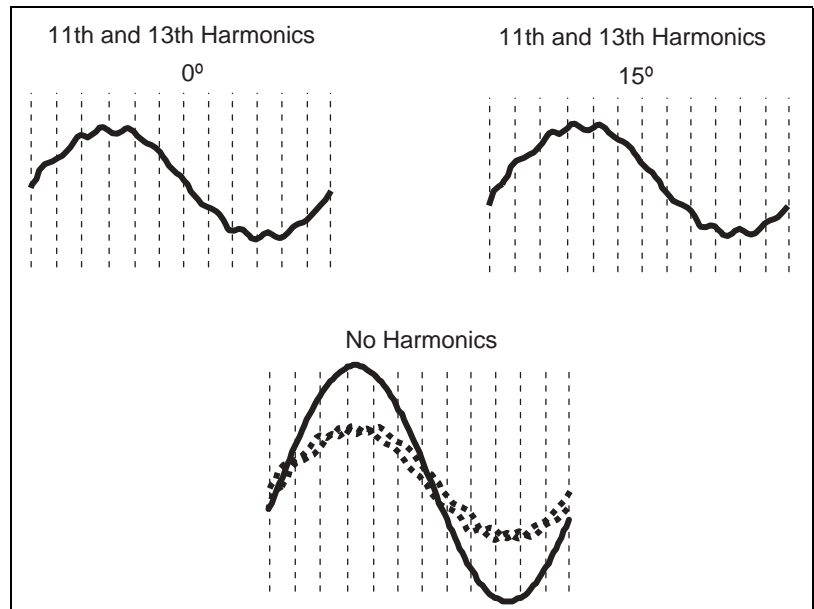

While the additional harmonic mitigation achieved in this last step may appear attractive, the additional benefit would be miniscule when compared to the additional cost involved, especially when the chance of this actually occurring in a realistic application is essentially zero.

**Electromagnetic Flux Cancellation**

Some HMTs are provided with a zigzag secondary winding. The zigzag winding has a beneficial effect on triplen harmonics ( $3^{rd}$ ,  $9^{th}$ ,  $15^{th}$ , ...) that have a similar phase angle.

**Figure 18: Some HMTs Are Offered As Delta-Zigzag or Wye-Zigzag**

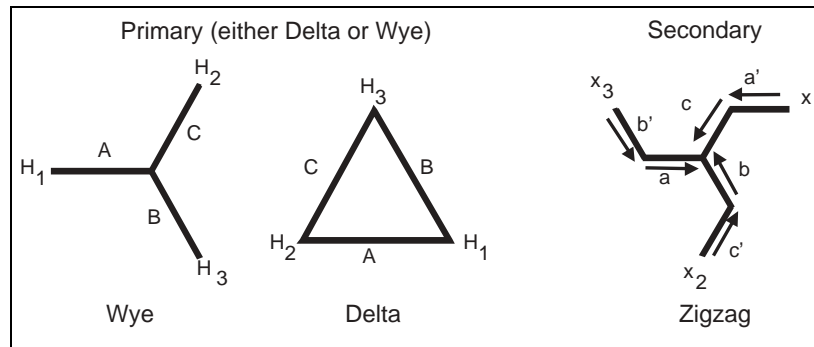

The zigzag is accomplished by winding half of the secondary turns of one phase of the transformer on one leg of the three-phase transformer, with the other half of the secondary turns on an adjacent phase as in Diagram 5. Another way to describe this is a' and a are wound on the same leg of the core, as are b' and b, and c' and c. With all of the triplen harmonics in phase

with each other, by vector analysis, the triplen harmonic currents produce ampere-turn fluxes that cancel each other such that no currents are induced in the primary winding. For this to work, the triplen harmonics must be real currents and not mere mathematical identities derived by the Fourier Transformation, a transformation that is commonly done by the computer in handheld meters or installed meters such as Powerlogic™ power metering devices or by other power monitoring devices.

### Zigzag Secondaries and Low Zero Sequence Impedance

Another characteristic of a zigzag transformer winding is its low impedance to zero sequence currents. The low zero sequence impedance of a zigzag is typically 20% of the value of the transformers positive and negative sequence impedance. Some manufacturers use this characteristic of the zigzag winding to attempt to differentiate the HMT from delta-wye transformers. The low zero sequence impedance has little to do with harmonic attenuation, and limiting the HMTs to a zigzag secondary attempts to prevent the use of the perfectly suitable delta-wye transformer. The equivalent construction delta-wye HMT offered by Square D is lighter and has a lower list price than the zigzag secondary HMTs.

### Harmonic Diversity

There is a misconception that the *k*-factors of electronic loads in parallel "average out." In fact, they do not. Typically, by the time 20 devices are on line simultaneously, the combined *k*-factor at the bus of the distribution panel is reduced by a factor of three or more. This is due to the fifth and higher order harmonics in the load current from multiple single-phase electronic loads on a given feeder occur at random phase angles, and constantly change in angle during operation.

Figure 19: Office Load Harmonic Phase Angle Patterns\*

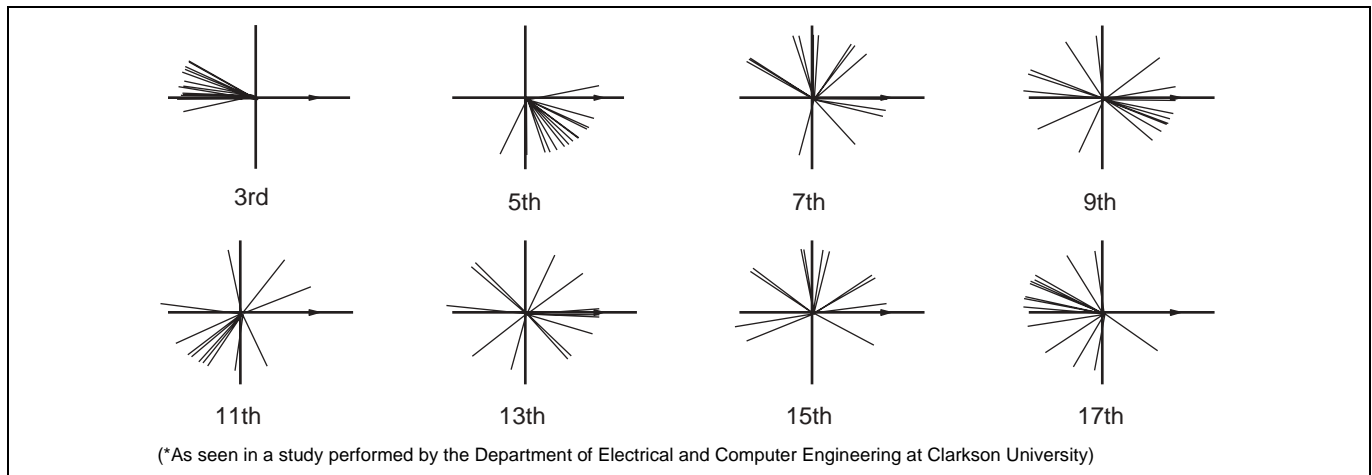

This random distribution of phase angles results in a dramatic reduction and/or cancellation of higher frequency harmonics. In fact, the higher the number of single-phase nonlinear loads on a given distribution panel, a lower *k*-factor will be seen at that panel.

While this is good for the overall electrical distribution system, the varying phase angle of the higher order harmonics will reduce, but not eliminate, the effectiveness of the HMT from the ideal as expressed in the theory discussed previously about sine wave combination.

**Efficiency**

Transformer operational efficiency has become a significant concern over the past several years. The culmination of which has brought about NEMA Standard TP 1-1996 (TP-1) that establishes minimum efficiency levels for low voltage, dry type distribution transformers at a 35% load. The 35% load is NEMA's conservative estimate on national average loading, and other surveys indicate that 17% may be a more accurate number. The HMTs offered by Square D comply with TP-1 and are ENERGY STAR® labeled.

**Comparing Efficiencies**

Rather than creating confusion when comparing different manufacturer's HMTs, note that when you compare similar types of transformers (delta-wye to delta-wye, or zigzag secondary to zigzag secondary) the transformers of similar connection will perform essentially the same with a given load regardless of it's harmonic profile. Thus it is unnecessary to differentiate between linear and non-linear load loss. All that is needed is the core loss (no load loss) and full load coil loss (conductor losses). If the duty cycle (the 24 hour average loading) is known, use the following calculation to obtain the average transformer loss (watts):

Average Loss at a given Duty Cycle (watts) = NL + ((PU<sup>2</sup>)\*FL)Where:

NL = core loss (no load loss) in watts

FL = full load coil loss (conductor loss) in watts

PU = the percent load expressed in per unit; to express the % load in per unit, take the percent load and express it as a decimal. For example, a 35% load expressed in per unit is 0.35.

To compare, transformers, simply obtain the no load (level) loss and the full load coil (conductor) loss for each.



Square D Company  
1010 Airpark Center Drive  
Nashville, TN, USA 37217  
1-888-SquareD (1-888-778-2733)  
[www.SquareD.com](http://www.SquareD.com)

Electrical equipment should be installed, operated, serviced, and maintained only by qualified personnel. No responsibility is assumed by Schneider Electric for any consequences arising out of the use of this material.

© 2003 Schneider Electric All Rights Reserved

