NetworkAIR™ AFX

Computer Room Air-Conditioning—60 Hz



Technical Data

Contents

Overview	1
Standard Features	2
Optional Features	4
Microprocessor Controller	6
Performance Specifications—Air Cooled	7
Performance Specifications—Water Cooled	9
Performance Specifications—Glycol Cooled	11
Electrical Data	13
Dimensional Data	14
Air-Cooled Condensers	18
Fluid Coolers	21
Pump Specifications	24
Guide Specifications	27
Guidelines for Installation	37

AFX	Model	Module	Configuration	Voltage	Reheat	Humidifier	Air Pattern
AFX	018	M= Main	A= Air Cooled	BA= 208-230/3/60	E= Electric	S= Steam Humidifier	D= Downflow
	065		W= Water Cooled	KA= 480/3/60			U= Upflow (front return)
			G=Glycol Cooled	MA= 600/3/60			

AFX XXX X X XX X X X

Overview

The APC NetworkAIR AFX computer room air conditioning system provides a quiet, efficient, and reliable solution for heat sensitive equipment areas.

Precision environmental requirements now reach far beyond the confines of the traditional data center or computer room to encompass a larger suite of applications, referred to as technology rooms. Critical environment applications include:

- Computer rooms
- Telecommunication facilities
- Clean rooms
- Power equipment
- Medical equipment rooms
- Archives
- LAN/WAN environments

A worldwide network of APC representatives is fully qualified to provide engineering, sales, installation and service for our products.

APC warrants all parts for 12 months from shipment. Extended warranties are available.

Models

AFX is available in two models: AFX18, AFX65.

Room Air Distribution

Downflow systems discharge air into the raised floor plenum. These systems are suitable for areas with raised floors greater than 12" (305 mm) high. Return air is drawn in through the top of the system.

Upflow systems discharge air into either a plenum or ductwork. These systems are suitable for areas without raised floors, as well as areas with raised floors. Air is drawn in through the front of the system.

Configuration

- Glycol Cooled
- Water Cooled
- Air Cooled

Compliance Approval

- ETL/CETL
- UL Listed to UL 1995 and CSA C22.2 No. 236
- MEA #223-99-E (City of New York)



Standard Features

- Scroll Compressor(s)
- Centrifugal Blower Assembly
- Heavy Gauge Steel Frame
- Main Power Circuit Breaker
- Microprocessor Controller
- Bearing Life, L₁₀ - 200,000 hrs
- Front Service Access Only
- Pure Steam Canister Humidifier
- 30% ASHRAE 52.1 Filters
- Three Phase Electric Reheat
- Environmental Monitoring
- Redundant Group Control
- Condensate Pump

Optional Features

- 2 or 3 Way Fluid Regulating Valves (Water or Glycol)
- Brazed Plate Condenser (Water or Glycol)
- Plenums (with or without grilles)
- Floorstand (with or without air deflectors, seismic)
- Discharge Duct Collar
- Downflow Return Duct
- ModBus/JBus Gateway
- OHE Disconnect
- Spot or Cable Water Detector(s)
- Firestat
- Smoke Detector
- Remote Relay Shutdown
- Reheat/Humidity or Compressor Lockout
- Remote Display and/or Sensor
- Hot Gas Bypass
- Secondary Drain Pan
- 3-Way Valve Flowswitch
- Custom Alarm Contacts

Standard Features

Cabinet

The frame is constructed of heavy gauge steel for maximum strength. Steel access panels are insulated for quieter operation. The unit has been designed for full service access from the front. The flush mounted panels are removable using convenient quarter-turn fasteners. The access doors for the electronic controller and electrical panel can be opened without interrupting the operation of the unit.

Evaporator Coil/Drain Pan

AFX utilizes dual distributors on one circuit of the refrigeration system. During dehumidification the smaller distributor is turned off, effectively reducing the active circuits of the evaporator coil. During this mode of operation the evaporating temperature is decreased, resulting in a lower coil surface temperature. This decreases the sensible heat ratio of the coil allowing a greater percentage of moisture removal. Additionally, the warmer air leaving the inactive circuits of the evaporator coil blends with the near saturated air from the active circuits raising the dry bulb temperature of the blended air well above saturation. Evaporator is a "V" coil, 1/2" rifled, copper tube, with raised, lanced, rippled, aluminum fins. Condensate pan is constructed of stainless steel.

Humidifier

The humidifier utilizes a pure steam generator specifically designed for hi-tech area environmental control. Pure steam eliminates contaminating mineral deposits, bacteria, white dust and excessive humidity. Automatic flushing combined with an indicator that signals when the canister is to be changed, ensure maintenance free operation.

Electrical Panel

The electrical panel contains the contactors, starters, overload protection devices, and input power disconnects. Each wire (except jumpers) is numbered every 3" (80mm), or color coded to facilitate circuit tracing when installing and servicing the unit. Each AC power circuit is individually branch circuit fused on all three phases. All compressor and motor devices are thermally and short circuit protected. The electrical panel is easily accessible from the front of the unit. An emergency cool override switch can be manually activated to initiate cooling and a field wired thermostat can be utilized to control cooling operation. Electrical components are UL-listed and -recognized and all wiring conforms to NFPA 70 (NEC) and UL 1995 requirements.

Air Filter

The filtration of conditioned air is extremely vital to maintaining the clean, particle-free environment required by electrical equipment. The system uses 30% efficient (100 microns) (ASHRAE 52.1-92), 4" (102 mm) deep filters, with full depth pleats. Deeper filters produce a lower pressure drop, requiring less energy during normal operation. Filters are replaceable through the front of the upflow unit and the top of the downflow unit.

Electric Reheat

A three-phase electrical resistance heater sized to offset the sensible cooling capacity in the dehumidification mode is incorporated in each NetworkAIR AFX. The reheat elements are low watt density sheathed components. The reheat is 3-phase to provide even phase loading. Reheat elements are electrically and thermally protected. The AFX18 is one stage and AFX65 is two stages.

Fan/Motor Section

The NetworkAIR AFX includes centrifugal blower assemblies that have been engineered for quiet, reliable operation. Lower blower speeds reduce noise and extend belt and bearing life to 200,000L₁₀ hours. Permanently lubricated bearings, a single-belt variable pitch drive, and an adjustable motor base all ensure dependable operation. In addition, the return air is evenly distributed across the cooling coil.

Main Power Disconnect

A nonautomatic main power circuit breaker disconnects all high voltage power to the unit. The disconnect switch is accessible without removing the electric box cover.

Refrigeration System and Compressor

The refrigeration system operates under an automatic microprocessor controller for greater efficiency and accuracy. The heavy-duty compressor is designed for year-round operation with a 15-year life expectancy. Performance of the refrigeration system is enhanced by use of Scroll Compressor Technology. Vibration in the system is greatly reduced by eliminating reciprocating masses found in the semi-hermetic compressor. Risk of refrigeration leaks at compressor gaskets are eliminated with the compressors' fully welded hermetic shell. The design of the scroll is more tolerant to liquid flood back than the traditional reciprocating compressor. Power consumption at full load is greatly reduced with higher EER's of the scroll. In addition reliability is enhanced due to the fewer moving parts required using scroll technology. The end result is a refrigeration system that offers the user optimized performance, efficiency, and reliability.

Redundant Group Control

Allows up to six NetworkAIR units the ability to communicate with each other to automatically switch upon alarm condition, or timed rotation. Can also allow standby units the ability to assist the running system.

Condensate Pump

The factory-installed and wired condensate pump will pump 36 gal/h (0.06 L/s) at 15 ft. (4.6 m) head.

Environmental Monitoring Unit

A stand-alone unit performs contact monitoring and continuous temperature and humidity sensing through two probes (one included). The unit is controlled by available web, control console, or SNMP interface with a network connection. In the event of an environmental anomaly, notification is sent via e-mail or SNMP. The unit is 18.25" x 9" x 2.75" (464mm x 229mm x 70mm).

Optional Features

Condenser

Water- and Glycol-cooled systems employ a brazed plate condenser that uses the latest heat transfer technology. Type 316L stainless plates are brazed together in a vacuum furnace and comply with ASME pressure vessel code. Pressure rating is 450 psi (3100 kPa).

Water-Regulating Valve

The Water-and Glycol systems maintain proper performance by sensing refrigerant discharge pressure and regulating the amount of water or glycol supplied to the condenser. A two-way or three-way valve is available. The standard valve pressure rating is 150 psi (1030kPa).

Discharge Duct Collar

A 1" (25.4 mm) duct flange is shipped loose from the factory for field installation to provide convenient connection to external ductwork for either supply or return as needed.

Secondary Drain Pan

Systems are provided with two drain pans. The primary stainless steel condensate drain pan lies directly under the cooling coil. A secondary emergency drain pan provides additional protection by catching and water before it reaches the subfloor and becomes a problem.

Spot Water Detector(s)

The solid-state spot water detector activates an audible alarm on the controller when moisture is detected.

Compressor Lockout

Prevents compressor operation in emergency situations where limited back-up power is available.

Cable Water Detector

A 20 ft. leak detection sensing cable is placed on the floor or subfloor around all possible leak sources. If water or other conductive liquids contact the cable anywhere along its length, an alarm is triggered.

Firestat

A firestat is available for factory installation in the air stream of the unit. If the return air temperature reaches 125°F (52°C), an audible and visual alarm on the microprocessor will be activated and the unit will immediately shutdown.

Smoke Detector

The factory-installed smoke detector is designed to sense smoke in the return air stream. Upon detection of smoke, an audible and visual alarm on the microprocessor will be activated and the unit will be immediately shutdown.

Remote Relay Shutdown

Shutdown of the NetworkAIR system can be done remotely by a factory installed relay. The relay can be ordered with a 24V, 120V, or 240V coil. The relay must be powered by others to disable the NetworkAIR system.

Reheat/Humidity Lockout

When facilities have limited backup power capacity, this lockout prevents the operation of electrical loads that are not essential for continued site operation.

Remote Display Panel

The microprocessor controller allows facility or building maintenance personnel to evaluate and control the unit from up to 50ft. away from the unit, without having to enter the secured space.

Remote Sensor(s)

Environmental sensor(s) can be strategically placed, up to 50ft. from the unit to better meet the site's cooling needs. The sensor must be positioned to permit air movement across the sensors.

Hot Gas Bypass

An auxiliary side-port hot gas bypass circuit. The activation of the hot gas bypass circuit will maintain the evaporator coil temperature during low load conditions. This optional feature will minimize compressor cycling and temperature fluctuations.

3-Way Valve Flow Switch

A Single-Pole, Double-Throw flow switch can be wired to energize one device and de-energize another device powered from the same source when fluid flow either exceeds or drops below the set flow rate.

Air Deflector

A field installed air deflector runs the length of the unit and attaches to the floorstand for changing air direction from vertical to horizontal.

Plenum

Air discharge plenums are available with upflow configurations. Heights are offered in 20" (508mm) and 24" (610mm). Manually adjustable, double deflecting grilles are provided on 3 or 4 sides.

OHE Disconnect

A non-fused disconnect switch may be wired to an outdoor heat exchanger to disconnect high voltage power if necessary.

Floorstand

The floorstand raises the unit above the subfloor to match the height of the raised floor. Heights are available (from 6" (142 mm) to 36" (914 mm)) in 3" (76.2 mm) increments and are adjustable +/- 1.5" (38.1 mm). APC recommends at least 12" (305 mm) high floorstands for their downflow units. Adjustment is provided by threaded pedestals. Vibration absorbing pads are included. The floorstand, pedestal, and pads ship loose. In areas where earthquakes are a concern, seismic floorstands are available in 12" (305mm), 18" (457 mm) and 24" (610 mm) heights.

Environmental Management System

A browser-accessible, 1U, rack-mountable appliance allows monitoring of environmental conditions. Monitoring of one temperature, one humidity, and one vibration sensor ship standard. When conditions change, notifications are sent via email to appropriate personnel. The EMS provides 8 input contacts, 2 output relays, and controllable power outlets for defining actions remotely should conditions warrant it.

ModBus/JBus Gateway

The Gateway translates transmission protocol from the system's network into ModBus/JBus communication protocol. One gateway can support up to 16 units.

Custom Alarm Contact Closures

Each unit is equipped with dry contact closures. Upon activation of the associated alarm, a discreet Normally open or Normally closed contact is available for remote monitoring of that discrete alarm.

Downflow Return Duct

A return duct the length and width of the unit may be field installed on a downflow unit to provide convenient connection to external ductwork.

Casters

A set of 6" plated rolling caster wheels are available for handling of equipment.

Microprocessor Controller

Microprocessor Controller

The microprocessor controller is standard on the main module of each system. The controller provides precision control for the demanding requirements of:

- Data centers
- Control rooms
- Clean rooms
- Switch rooms
- UPS rooms

The easy-to-use display allows the operator to select options from the device's menu-driven interface to control and monitor the connected air conditioning system.

Status

Complete status monitoring is provided within the status menu of the microprocessor controller. Available information includes:

- Current Temperature/Humidity
- Temperature/Humidity Setpoint
- Cooling/Heating Status
- Humidification/Dehumidification Status

Alarms

Quick access to any alarm condition is facilitated through the menu structure. The alarm key acts as a hot key providing immediate access to the alarm display menu. Presence of a new alarm will sound the audible alarm. The red alarm LED on the display panel will remain illuminated until all alarms have been cleared. The temperature and humidity alarm setpoints are adjustable. Alarm annunciations include:

- Loss of airflow
- Clogged filter
- High head pressure
- Low suction pressure
- High/Low temperature
- High/Low humidity

Automatic setpoint crossover protection will prevent the setting of the heat setpoint above the cool setpoint and the humidification setpoint above the dehumidification setpoint. Setpoint adjustment can be restricted to only operators with knowledge of the security codes set within the security menu structure.

Configuration

Flexibility is offered through the use of the configuration menu. Operating requirements are satisfied by changing the configuration settings. New configurations are stored in EEPROM and protected from unauthorized tampering by the four-digit security password, selected in the security menu. Configuration options include:

- Fahrenheit or celsius display
- Compressor minimum on/off time
- Power loss restart time delay
- Redundant unit grouping
- Alarm input polarity
- Alarm enable
- Temperature/Humidity deadbands
- Small room delay

Common Alarm Contact

A common alarm relay is installed on every microprocessor. In the event of an alarm condition, the relay will change state. The user can select which alarms change the state of the relay. This feature allows for remote enunciation of alarm status.

Run Times

The major components within the unit have independent run timers that monitor and store accumulated run hours on the components. The run timers are provided with operator adjustable run time alarms.

Security

Multiple security levels prevent unauthorized adjustment of important system parameters. The user may select a four-digit password for setpoint and configuration changes. Should the password be forgotten, APC can provide temporary access.

Monitoring

With the addition of a supervisory network communications card the microprocessor may interface with the locally installed APC remote monitoring and control system. Gateways are available for interfacing with building management systems. Please check with APC for compatibility with your building management system.

Cool Inhibit

Prevents the unit from over-cooling during the dehumidification cycle. If the space temperature falls below a user adjustable setpoint, cooling will become inhibited until the space temperature returns to setpoint.

Cool Override

A manual toggle switch will allow the compressor to operate in the event of a microprocessor failure. The cool override can be field wired to a snap acting thermostat for cooling control.

Remote Shutdown

Events external to the unit, such as activation of a fire suppression system may require the unit to shut down remotely. Additionally this feature may be tied into a BMS that would allow remote control of the units on/off status.

Performance Specifications—Air Cooled

AFX MODEL*	AFX018	AFX065
80F DB, 67F WB (26.7C DB, 19.4C WB) 50% RH		
Total - BTU/HR (kW)	75,000 (22.0)	287,000 (84.0)
Sensible - BTU/HR (kW)	63,000 (19.0)	228,000 (67.0)
75F DB, 62.5F WB (23.9C DB, 16.9C WB) 50% RH		
Total - BTU/HR (kW)	69,000 (20.0)	265,000 (78.0)
Sensible - BTU/HR (kW)	63,000 (18.0)	226,000 (66.0)
75F DB, 61F WB (23.9C DB, 16.1C WB) 45% RH		
Total - BTU/HR (kW)	68,000 (20.0)	260,000 (76.0)
Sensible - BTU/HR (kW)	68,000 (20.0)	245,000 (72.0)
72F DB, 60F WB (22.2C DB, 15.5C WB) 50% RH		
Total - BTU/HR (kW)	66,000 (19.0)	253,000 (74.0)
Sensible - BTU/HR (kW)**	61,000 (18.0)	221,000 (65.0)
72F DB, 58.6 WB (22.2D DB, 14.8C WB) 45% RH		
Total - BTU/HR (kW)	65,000 (19.0)	249,000 (73.0)
Sensible - BTU/HR (kW)	65,000 (19.0)	238,000 (70.0)
70F DB, 58.5F WB (21.1C DB, 14.8C WB) 50% RH		
Total - BTU/HR (kW)	63,000 (19.0)	245,000 (72.0)
Sensible - BTU/HR (kW)	59,000 (17.0)	215,000 (63.0)
70F DB, 57.2F WB (21.1C DB, 14.0C WB) 45% RH		
Total - BTU/HR (kW)	63,000 (18.0)	242,000 (71.0)
Sensible - BTU/HR (kW)	63,000 (18.0)	231,000 (68.0)
AIR SYSTEM -- BELT DRIVE CENTRIFUGAL		
Air Volume -- CFM (L/s)	3,600 (1,699)	12,000 (5,663)
Blower Motor -- HP (kW)	3 (2.2)	5 (3.7)
External Static Pressure -- inches of water (Pa)	0.5 (124)	0.5 (124)
Number of Blowers/Motors	1	3
COMPRESSOR -- SCROLL		
EER	14.6	14.6
Quantity	1	2
EVAPORATOR COIL -- V FRAME, COPPER TUBE/ALUMINUM FIN		
Face Area -- ft ² (m ²)	9.5 (0.88)	33.0 (3.07)
Rows Deep	4	4
Face Velocity -- FPM (m/s)	380 (1.93)	364 (1.85)
HUMIDIFICATION --- SOLID STATE ELECTRODE CANISTER		
Flush Cycle	automatic	automatic
Capacity -- Lbs/hr (Kg/hr)	10 (4.5)	20 (9.0)
kW	3.4	6.8
FILTERS		
Quantity	2	6
Depth -- Inches (mm)	4 (102)	4 (102)
Size (Downflow) -- Inches (mm)	30 x 15.5 (762 x394)	30 x 15.5 (762 x394)
Size (Upflow) -- Inches (mm)	27 x 18 (686 x457)	27 x 18 (686 x457)
REHEAT		
Electric -- Equally Loaded Three (3) Phase, Finned Tubular, Low-Watt Density		
Capacity -- BTU/HR (kW) Includes Motor Heat***	28,000 (8.3)	85,000 (24.9)
Stages	1	2
Hot Water -- 180F (82.2C) EWT, 160F (71.1C) LWT		
Capacity -- BTU/HR (kW) Includes Motor Heat	79,000 (23.0)	268,000 (78.3)
GPM (L/s)	7.8 (0.49)	26.4 (1.67)
Pressure Drop -- PSI (kPa)	0.3 (1.8)	2.7 (18.6)
Steam -- 15 psig (103.3 kPa)		
Capacity -- BTU/HR (kW) Includes Motor Heat	79,000 (23.0)	273,000 (79.9)
Control Valve	solenoid	solenoid
PHYSICAL DATA		
Weight -- lbs (kg)	850 (386)	1,900 (862)
Height -- Inches (mm)	76.0 (1,930)	76.0 (1,930)
Length -- Inches (mm)	34.4 (873)	98.3 (2,997)
Depth -- Inches (mm)	34.4 (873)	34.4 (873)

*Rated Capacity +/-10%

**Nominal Rating Point

***With equal loading on each phase, rated at 208-230V / 3-phase, 480V / 3-phase and 600V / 3-phase

Performance Specifications - Air Cooled

AFX MODEL	AFX018	AFX065
CONNECTION SIZES****		
Air		
Liquid Line -- inches OD	1/2	5/8
Discharge Line -- inches OD	5/8	1-1/8
Hot Water		
Supply Line -- inches OD	5/8	7/8
Return Line -- inches OD	5/8	7/8
Steam		
Supply Line -- inches OD	5/8	7/8
Humidifier		
Supply Line -- inches OD	1/4	1/4
Condensate Drain		
Drain Line -- inches ID	7/8	7/8

****Connections sizes, not recommended piping sizes

Performance Specifications—Water Cooled

AFX MODEL*	AFX018	AFX065
80F DB, 67F WB (26.7C DB, 19.4C WB) 50% RH		
Total - BTU/HR (kW)	81,000 (24.0)	314,000 (92.0)
Sensible - BTU/HR (kW)	66,000 (19.0)	239,000 (70.0)
75F DB, 62.5F WB (23.9C DB, 16.9C WB) 50% RH		
Total - BTU/HR (kW)	74,000 (2320)	287,000 (84.0)
Sensible - BTU/HR (kW)	65,000 (18.0)	235,000 (69.0)
75F DB, 61F WB (23.9C DB, 16.1C WB) 45% RH		
Total - BTU/HR (kW)	73,000 (21.0)	280,000 (82.0)
Sensible - BTU/HR (kW)	70,000 (20.0)	254,000 (74.0)
72F DB, 60F WB (22.2C DB, 15.5C WB) 50% RH		
Total - BTU/HR (kW)	70,000 (21.0)	272,000 (80.0)
Sensible - BTU/HR (kW)**	63,000 (18.0)	229,000 (67.0)
72F DB, 58.6 WB (22.2D DB, 14.8C WB) 45% RH		
Total - BTU/HR (kW)	70,000 (21.0)	267,000 (78.0)
Sensible - BTU/HR (kW)	68,000 (20.0)	247,000 (72.0)
70F DB, 58.5F WB (21.1C DB, 14.8C WB) 50% RH		
Total - BTU/HR (kW)	68,000 (20.0)	264,000 (77.0)
Sensible - BTU/HR (kW)	61,000 (19.0)	224,000 (66.0)
70F DB, 57.2F WB (21.1C DB, 14.0C WB) 45% RH		
Total - BTU/HR (kW)	68,000 (20.0)	259,000 (76.0)
Sensible - BTU/HR (kW)	66,000 (19.0)	240,000 (70.0)
COOLANT REQUIREMENTS		
THR -- MBH (kW)	112,000 (33.0)	436,000 (128.0)
65 F (18.3 C) Water In -- GPM (L/s)	6.1 (0.4)	22.6 (1.4)
Pressure Drop -- psig (kPa)	1.4 (10)	2.0 (14)
75 F (23.9 C) Water In -- GPM (L/s)	8.1 (0.5)	30.2 (1.9)
Pressure Drop -- psig (kPa)	2.5 (17)	3.5 (24)
85 F (29.4 C) Water In -- GPM (L/s)	18.2 (1.2)	64.5 (4.1)
Pressure Drop -- psig (kPa)	11.8 (81)	15.6 (108)
WATER REGULATING VALVES		
Size -- 2 Way Ball Valve -- Inches, NPT (Cv)***	1 x 1-1/4 (14)	2 x 1-1/2 (40)
Size -- 3 Way Ball Valve -- Inches, NPT (Cv)****	1 x 1-1/4 (14)	2 x 1-1/2 (40)
AIR SYSTEM -- BELT DRIVE CENTRIFUGAL		
Air Volume -- CFM (L/s)	3,600 (1,699)	12,000 (5,663)
Blower Motor -- HP (kW)	3 (2.2)	5 (3.7)
External Static Pressure -- inches of water (Pa)	0.5 (124)	0.5 (124)
Number of Blowers/Motors	1	3
COMPRESSOR -- SCROLL		
EER	18.7	18.3
Quantity	1	2
EVAPORATOR COIL -- V FRAME, COPPER TUBE/ALUMINUM FIN		
Face Area -- ft ² (m ²)	9.5 (0.88)	33.0 (3.07)
Rows Deep	4	4
Face Velocity -- FPM (m/s)	380 (1.93)	364 (1.85)
HUMIDIFICATION --- SOLID STATE ELECTRODE CANISTER		
Flush Cycle	automatic	automatic
Capacity -- Lbs/hr (Kg/hr)	10 (4.5)	20 (9.0)
kW	3.4	6.8
FILTERS		
Quantity	2	6
Depth -- Inches (mm)	4 (102)	4 (102)
Size (Downflow) -- Inches (mm)	30 x 15.5 (762 x394)	30 x 15.5 (762 x394)
Size (Upflow) -- Inches (mm)	27 x 18 (686 x457)	27 x 18 (686 x457)

*Rated Capacity +/-10%

**Nominal Rating Point

***2-Way Single Seated, 400 psig W.W.P. max

****3-Way Single Seated, 400 psig W.W.P. max

Performance Specifications—Water Cooled

AFX MODEL	AFX018	AFX065
REHEAT		
Electric -- Equally Loaded Three (3) Phase, Finned Tubular, Low-Watt Density		
Capacity -- BTU/HR (kW) Includes Motor Heat*****	28,000 (8.3)	85,000 (24.9)
Stages	1	2
Hot Water -- 180F (82.2C) EWT, 160F (71.1C) LWT		
Capacity - BTU/HR (kW) Includes Motor Heat	79,000 (23.0)	268,000 (78.3)
GPM (L/s)	7.8 (0.49)	26.4 (1.67)
Pressure Drop -- PSI (kPA)	0.3 (1.8)	2.7 (18.6)
Hot Gas Reheat		
Capacity -- BTU/HR (kW) Includes Motor Heat	26,000 (7.6)	147,000 (43.0)
Steam -- 15 psig (103.3 kPa)		
Capacity -- BTU/HR (kW) Includes Motor Heat	79,000 (23.0)	273,000 (79.9)
Control Valve	solenoid	solenoid
PHYSICAL DATA		
Weight -- lbs (kg)	1,000 (454)	2,700 (1,227)
Height -- Inches (mm)	76.0 (1,930)	76.0 (1,930)
Length -- Inches (mm)	34.4 (873)	98.3 (2,997)
Depth -- Inches (mm)	34.4 (873)	34.4 (873)
CONNECTION SIZES*****		
Water In/Out -- Inches OD	1-3/8	2-1/8
Hot Water		
Supply Line -- Inches OD	5/8	7/8
Return Line -- Inches OD	5/8	7/8
Steam		
Supply Line -- Inches OD	5/8	7/8
Humidifier		
Supply Line -- Inches OD	1/4	1/4
Condensate Drain		
Drain Line -- Inches ID	7/8	7/8

*****With equal loading on each phase, rated at 208-230V / 3-phase, 480V / 3-phase and 600V / 3-phase

*****Connections sizes, not recommended piping sizes

Performance Specifications—Glycol Cooled

AFX MODEL*	AFX018	AFX065
80F DB, 67F WB (26.7C DB, 19.4C WB) 50% RH		
Total - BTU/HR (kW)	74,000 (21.0)	277,000 (81.0)
Sensible - BTU/HR (kW)	63,000 (18.0)	224,000 (66.0)
75F DB, 62.5F WB (23.9C DB, 16.9C WB) 50% RH		
Total - BTU/HR (kW)	67,000 (20.0)	257,000 (75.0)
Sensible - BTU/HR (kW)	62,000 (18.0)	222,000 (65.0)
75F DB, 61F WB (23.9C DB, 16.1C WB) 45% RH		
Total - BTU/HR (kW)	67,000 (20.0)	252,000 (74.0)
Sensible - BTU/HR (kW)	66,000 (19.0)	241,000 (71.0)
72F DB, 60F WB (22.2C DB, 15.5C WB) 50% RH		
Total - BTU/HR (kW)	64,000 (19.0)	245,000 (72.0)
Sensible - BTU/HR (kW)**	60,000 (17.0)	217,000 (64.0)
72F DB, 58.6 WB (22.2D DB, 14.8C WB) 45% RH		
Total - BTU/HR (kW)	64,000 (19.0)	241,000 (71.0)
Sensible - BTU/HR (kW)	64,000 (19.0)	234,000 (69.0)
70F DB, 58.5F WB (21.1C DB, 14.8C WB) 50% RH		
Total - BTU/HR (kW)	62,000 (18.0)	238,000 (70.0)
Sensible - BTU/HR (kW)	58,000 (16.0)	212,000 (62.0)
70F DB, 57.2F WB (21.1C DB, 14.0C WB) 45% RH		
Total - BTU/HR (kW)	62,000 (18.0)	235,000 (69.0)
Sensible - BTU/HR (kW)	62,000 (18.0)	227,000 (67.0)
COOLANT REQUIREMENTS		
THR -- MBH (kW)	107,000 (31.0)	419,000 (123.0)
105 F (40.6 C) Glycol In -- GPM (L/s)	17.2 (1.1)	65.6 (4.1)
Pressure Drop -- psig (kPa)	5.2 (36)	9.4 (65)
WATER REGULATING VALVES		
Size -- 2 Way Ball Valve -- Inches, NPT (Cv)***	1 x 1-1/4 (14)	2 x 1-1/2 (40)
Size -- 3 Way Ball Valve -- Inches, NPT (Cv)****	1 x 1-1/4 (14)	2 x 1-1/2 (40)
AIR SYSTEM -- BELT DRIVE CENTRIFUGAL		
Air Volume -- CFM (L/s)	3,600 (1,699)	12,000 (5,663)
Blower Motor -- HP (kW)	3 (2.2)	5 (3.7)
External Static Pressure -- inches of water (Pa)	0.5 (124)	0.5 (124)
Number of Blowers/Motors	1	3
COMPRESSOR -- SCROLL		
EER	13.4	13.4
Quantity	1	2
EVAPORATOR COIL -- V FRAME, COPPER TUBE/ALUMINUM FIN		
Face Area -- ft ² (m ²)	9.5 (0.88)	33.0 (3.07)
Rows Deep	4	4
Face Velocity -- FPM (m/s)	380 (1.93)	364 (1.85)
HUMIDIFICATION --- SOLID STATE ELECTRODE CANISTER		
Flush Cycle	automatic	automatic
Capacity -- Lbs/hr (Kg/hr)	10 (4.5)	20 (9.0)
kW	3.4	6.8
FILTERS		
Quantity	2	6
Depth -- Inches (mm)	4 (102)	4 (102)
Size (Downflow) -- Inches (mm)	30 x 15.5 (762 x394)	30 x 15.5 (762 x394)
Size (Upflow) -- Inches (mm)	27 x 18 (686 x457)	27 x 18 (686 x457)
REHEAT		
Electric -- Equally Loaded Three (3) Phase, Finned Tubular, Low-Watt Density		
Capacity -- BTU/HR (kW) Includes Motor Heat*****	28,000 (8.3)	85,000 (24.9)
Stages	1	2
Hot Water -- 180F (82.2C) EWT, 160F (71.1C) LWT		
Capacity - BTU/HR (kW) Includes Motor Heat	79,000 (23.0)	268,000 (78.3)
GPM (L/s)	7.8 (0.49)	26.4 (1.67)
Pressure Drop -- PSI (kPa)	0.3 (1.8)	2.7 (18.6)
Hot Gas Reheat		
Capacity -- BTU/HR (kW) Includes Motor Heat	26,000 (7.6)	147,000 (43.0)
Steam -- 15 psig (103.3 kPa)		
Capacity -- BTU/HR (kW) Includes Motor Heat	79,000 (23.0)	273,000 (79.9)
Control Valve	solenoid	solenoid

*Rated Capacity +/-10%

**Nominal Rating Point

***2-Way Single Seated, 400 psig W.W.P. max

****3-Way Single Seated, 400 psig W.W.P. max

*****With equal loading on each phase, rated at 208-230V / 3-phase, 480V / 3-phase and 600V / 3-phase

Performance Specifications—Glycol Cooled

AFX MODEL	AFX018	AFX065
PHYSICAL DATA		
Weight -- lbs (kg)	1,000 (454)	2,700 (1,227)
Height -- Inches (mm)	76.0 (1,930)	76.0 (1,930)
Length -- Inches (mm)	34.4 (873)	98.3 (2,997)
Depth -- Inches (mm)	34.4 (873)	34.4 (873)
CONNECTION SIZES*****		
Glycol In/Out -- Inches OD	1-3/8	2-1/8
Hot Water		
Supply Line -- Inches OD	5/8	7/8
Return Line -- Inches OD	5/8	7/8
Steam		
Supply Line -- Inches OD	5/8	7/8
Humidifier		
Supply Line -- Inches OD	1/4	1/4
Condensate Drain		
Drain Line -- Inches ID	7/8	7/8

*****Connections sizes, not recommended piping sizes

Electrical Data

AIR COOLED

REHEAT		Electric				Hot Gas, Steam, Hot Water or None				Electric				Hot Gas, Steam, Hot Water or None			
HUMIDIFIER		Electrode Canister - Steam				Electrode Canister - Steam				Steam or None				Steam or None			
VOLTAGE		208	230	480	600	208	230	480	600	208	230	480	600	208	230	480	600
AFX018	FLA	42.4	42.4	21.1	17.5	42.4	40.0	19.9	16.0	41.6	42.4	21.1	17.5	26.0	25.2	12.5	10.0
	WSA	55.2	55.4	27.3	22.8	55.2	52.4	25.8	21.0	55.2	55.4	27.3	22.8	34.7	33.9	16.5	13.5
	MOP	70.0	70.0	35.0	30.0	70.0	60.0	30.0	25.0	70.0	70.0	35.0	25.0	50.0	50.0	25.0	20.0
AFX065	FLA	136.9	126.6	54.2	52.3	136.9	125.4	53.6	50.0	127.7	126.6	54.2	52.3	117.9	108.4	45.1	43.1
	WSA	174.1	169.2	77.8	64.7	174.1	169.2	75.7	61.0	161.8	165.4	77.8	64.7	150.4	148.0	65.1	52.4
	MOP	200.0	200.0	90.0	70.0	200.0	200.0	90.0	90.0	175.0	175.0	90.0	70.0	175.0	175.0	80.0	60.0

WATER COOLED

REHEAT		Electric				Hot Gas, Steam, Hot Water or None				Electric				Hot Gas, Steam, Hot Water or None			
HUMIDIFIER		Electrode Canister - Steam				Electrode Canister - Steam				Steam or None				Steam or None			
VOLTAGE		208	230	480	600	208	230	480	600	208	230	480	600	208	230	480	600
AFX018	FLA	40.1	40.1	20.0	16.5	40.1	37.7	18.8	15.0	39.3	40.1	20.0	16.5	23.7	22.9	11.4	9.0
	WSA	55.2	55.4	27.3	22.8	55.2	52.4	25.8	21.0	55.2	55.4	27.3	22.8	34.7	33.9	16.5	13.5
	MOP	70.0	70.0	35.0	30.0	70.0	60.0	30.0	25.0	70.0	70.0	35.0	25.0	50.0	50.0	25.0	20.0
AFX065	FLA	128.5	122.8	52.3	50.8	128.5	117.8	49.8	47.0	123.5	122.8	52.3	50.8	109.5	100.8	41.3	40.1
	WSA	174.1	169.2	77.8	64.7	174.1	169.2	75.7	61.0	161.8	165.4	77.8	64.7	150.4	148.0	65.1	52.4
	MOP	200.0	200.0	90.0	70.0	200.0	200.0	90.0	90.0	175.0	175.0	90.0	70.0	175.0	175.0	80.0	60.0

GLYCOL COOLED

REHEAT		Electric				Hot Gas, Steam, Hot Water or None				Electric				Hot Gas, Steam, Hot Water or None			
HUMIDIFIER		Electrode Canister - Steam				Electrode Canister - Steam				Steam or None				Steam or None			
VOLTAGE		208	230	480	600	208	230	480	600	208	230	480	600	208	230	480	600
AFX018	FLA	43.9	43.9	21.9	18.1	43.9	41.5	20.7	16.6	43.1	43.9	21.9	18.1	27.5	26.7	13.3	10.6
	WSA	55.2	55.4	27.3	22.8	55.2	52.4	25.8	21.0	55.2	55.4	27.3	22.8	34.7	33.9	16.5	13.5
	MOP	70.0	70.0	35.0	30.0	70.0	60.0	30.0	25.0	70.0	70.0	35.0	25.0	50.0	50.0	25.0	20.0
AFX065	FLA	140.4	128.6	55.2	52.9	140.4	128.6	55.2	51.3	129.5	128.2	55.0	52.9	121.4	111.6	46.7	44.4
	WSA	174.1	169.2	77.8	64.7	174.1	169.2	75.7	61.0	161.8	165.4	77.8	64.7	150.4	148.0	65.1	52.4
	MOP	200.0	200.0	90.0	70.0	200.0	200.0	90.0	90.0	175.0	175.0	90.0	70.0	175.0	175.0	80.0	60.0

FLA = Full Load Amps

WSA = Wire Size Amps

MOP = Maximum Overcurrent Protection

Dimensional Data

Downflow - AFX018

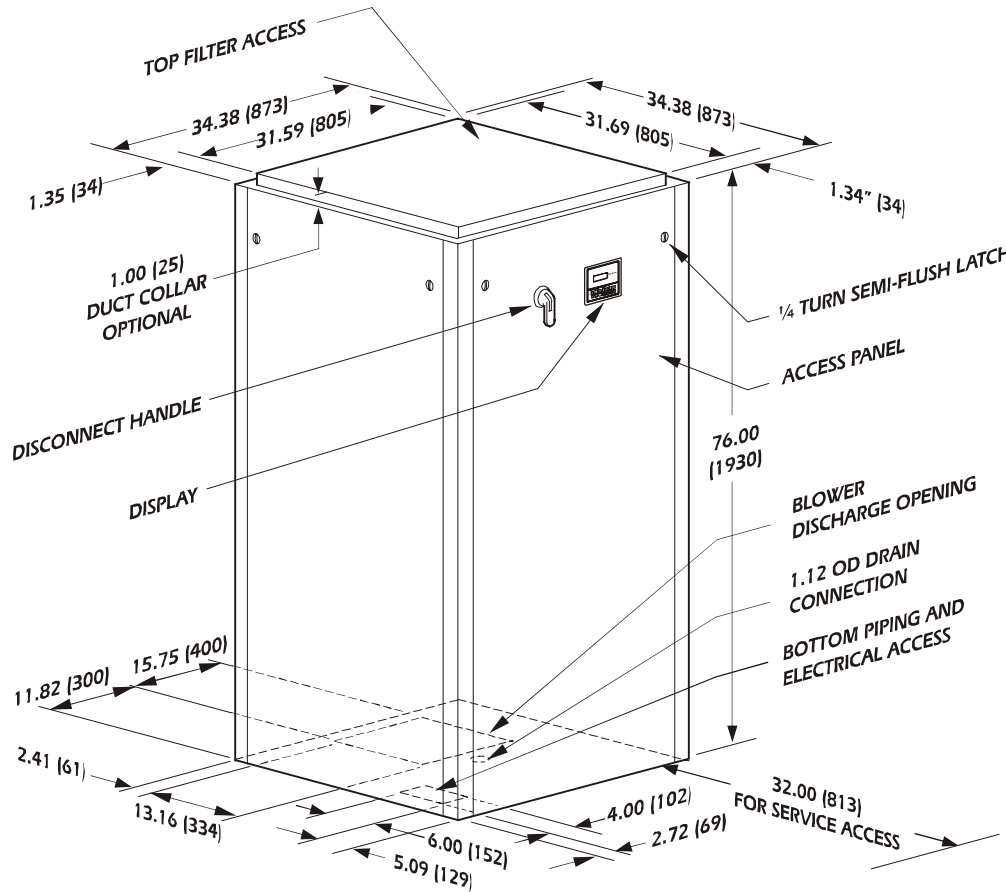

* All dimensions are in inches (mm).

Downflow - AFX065

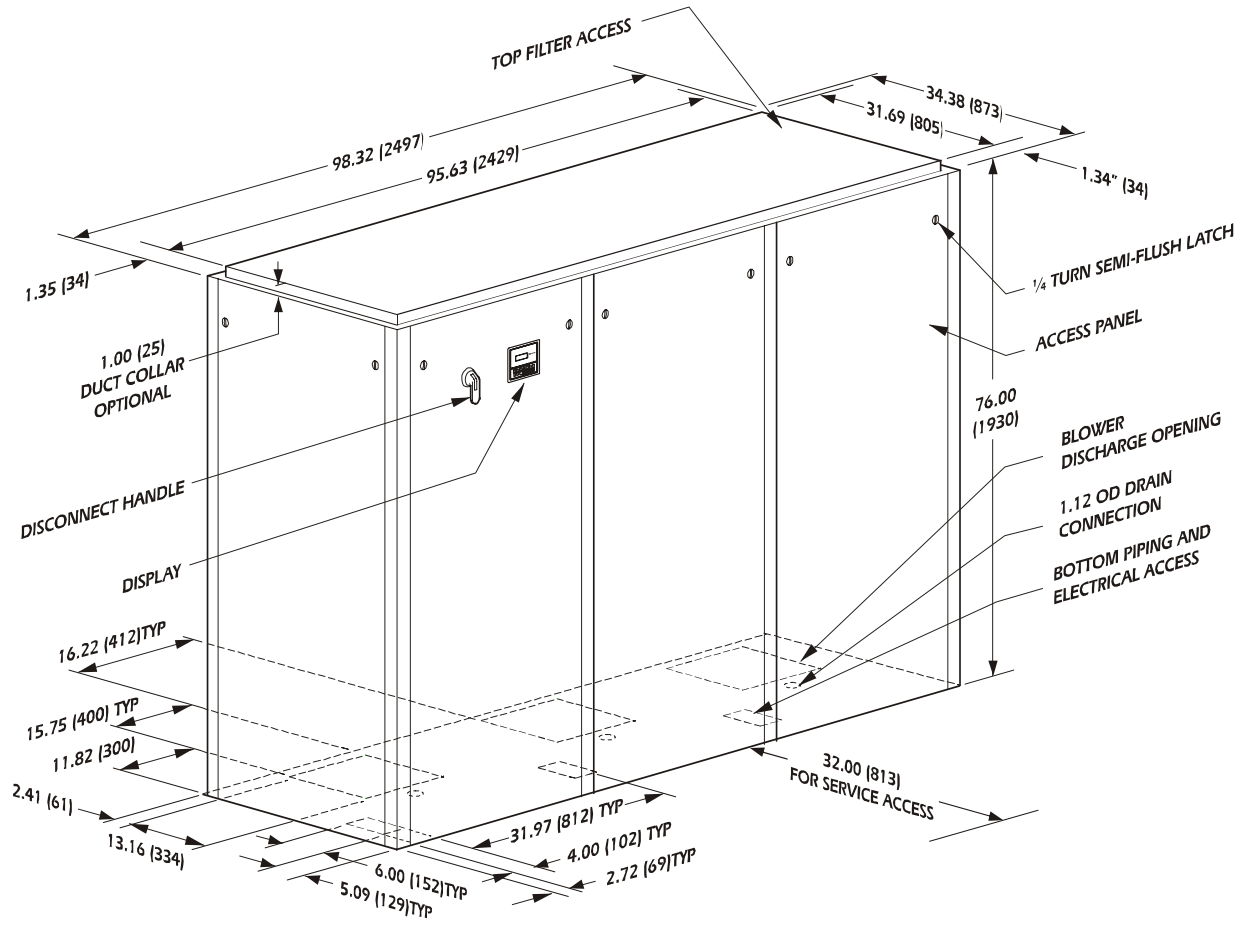

* All dimensions are in inches (mm).

Upflow front return - AFX018

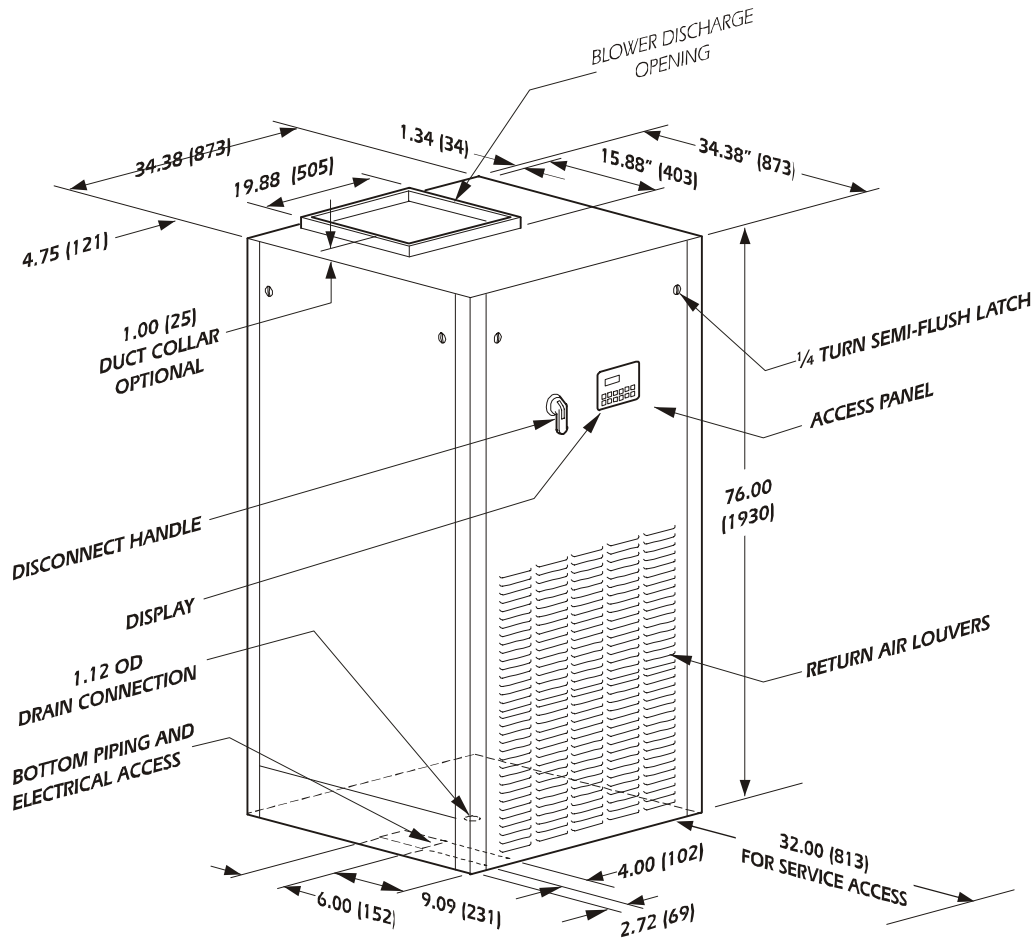

* All dimensions are in inches (mm).

Upflow front return- AFX065

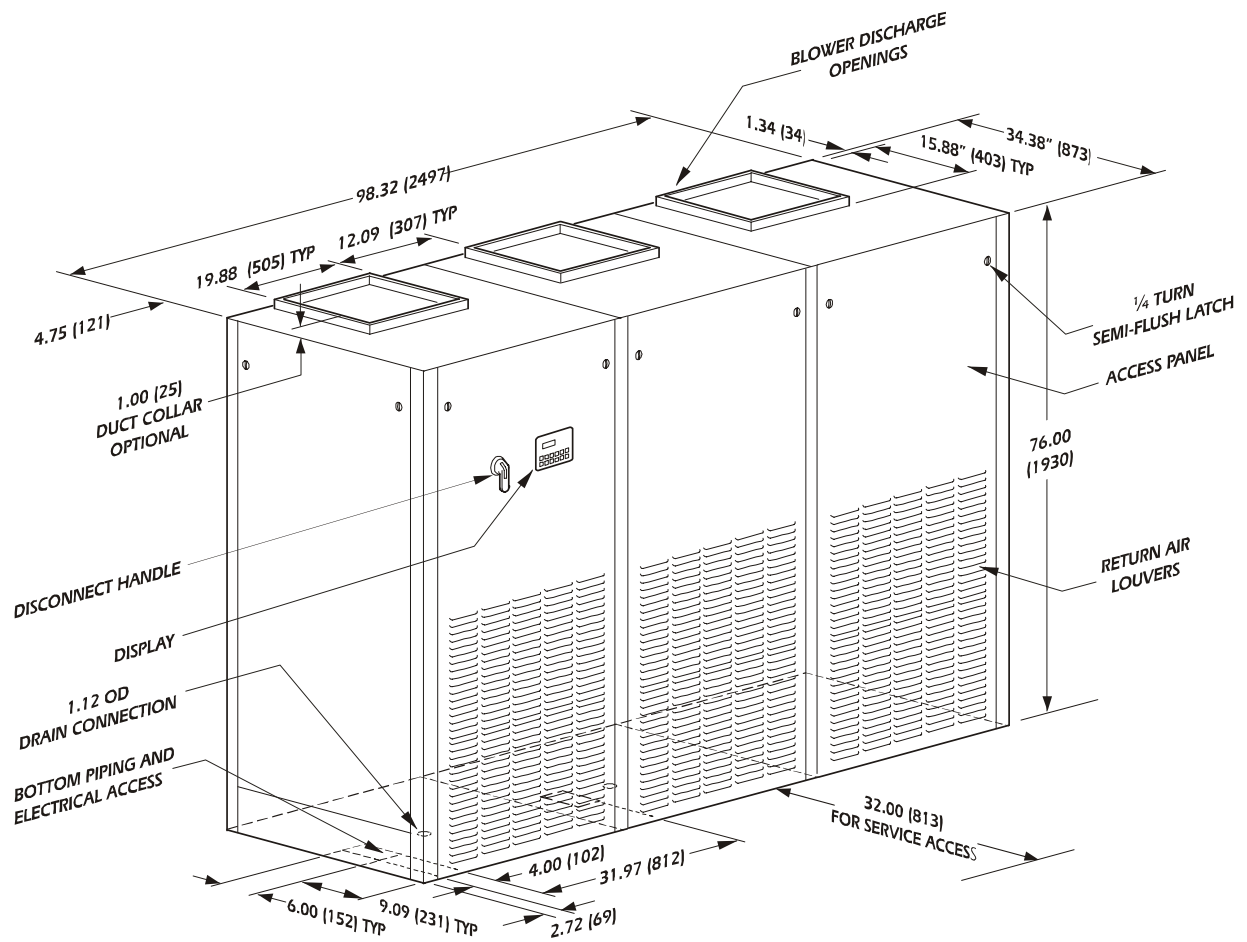

* All dimensions are in inches (mm).

Air-Cooled Condensers

Air-cooled condenser—performance/electrical data

OHE SKU	Voltage	Ambient Temperature			Air Quantity		# of Circuits	Fan/Motor			Connection		Weight		Electrical Data		
		95F	105F	115F	CFM	L/s		Qty.	HP	RPM	Hot Gas	Liquid	Lbs	Kg	FLA	MCA	MOP
ACCD75018	208-230/1/60	018	018	N/A	6,450	3,044	1	1	1/2	1075	1-1/8	7/8	260	118	3.9	4.9	15.0
ACCD75019	480/1/60	018	018	N/A	6,450	3,044	1	1	1/2	1075	1-1/8	7/8	260	118	2.0	2.4	15.0
ACCD75022	208-230/3/60	N/A	N/A	018	10,10	4,766	1	2	1/3	1140	1-1/8	7/8	450	204	5.2	5.9	15.0
ACCD75023	480/3/60	N/A	N/A	018	10,10	4,766	1	2	1/3	1140	1-1/8	7/8	450	204	2.6	2.9	15.0
ACCD75150	600/3/60	N/A	N/A	018	10,10	4,766	1	2	1/3	1140	1-1/8	7/8	450	204	2.1	2.4	15.0
ACCD75096	208-230/3/60	065	065	N/A	20,70	9,768	2	3	1-1/2	1140	1-5/8	1-5/8	880	400	14.0	15.8	20.0
ACCD75097	480/3/60	065	065	N/A	20,70	9,768	2	3	1-1/2	1140	1-5/8	1-5/8	880	400	7.0	7.9	15.0
ACCD75163	600/3/60	065	065	N/A	20,70	9,768	2	3	1-1/2	1140	1-5/8	1-5/8	880	400	5.6	6.3	15.0
ACCD75100	208-230/3/60	N/A	N/A	065	34,80	16,42	2	3	1-1/2	1140	2-1/8	2-1/8	1,190	540	21.0	22.8	25.0
ACCD75101	480/3/60	N/A	N/A	065	34,80	16,42	2	3	1-1/2	1140	2-1/8	2-1/8	1,190	540	10.5	11.4	15.0
ACCD75165	600/3/60	N/A	N/A	065	34,80	16,42	2	3	1-1/2	1140	2-1/8	2-1/8	1,190	540	8.4	9.1	15.0

FLA = Full Load Amps

MCA = Minimum Circuit Amperes

MOP = Maximum Overcurrent Protection

1-fan air-cooled condenser

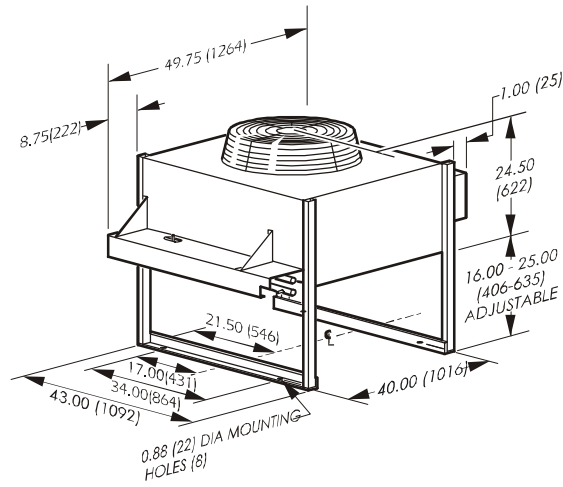

APC PART	CIRCUIT	VOLTAGE
ACCD75018	single	208-230/1/60
ACCD75019	single	480/1/60

2-fan air-cooled condenser

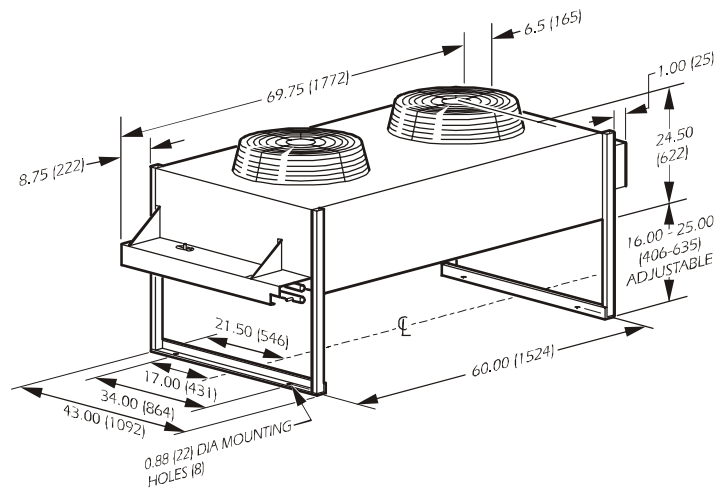

APC PART	CIRCUIT	VOLTAGE
ACCD75022	single	208-230/3/60
ACCD75023	single	480/3/60
ACCD75150	single	600/3/60

2-fan air-cooled condenser

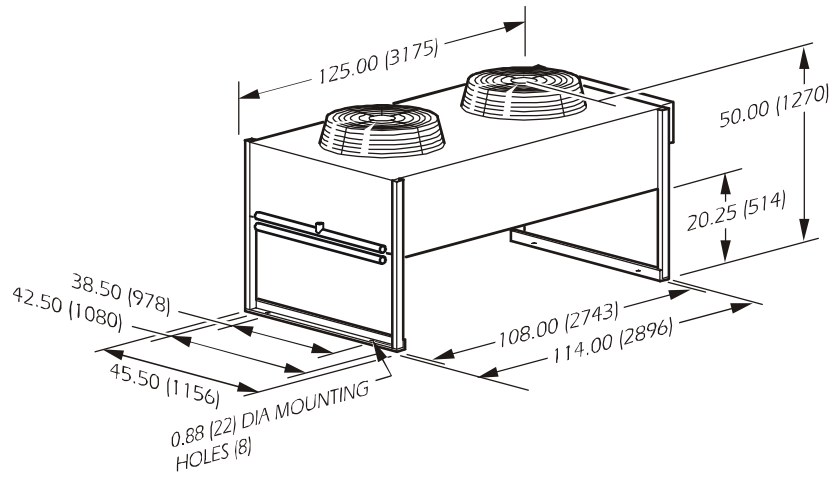

APC PART	CIRCUIT	VOLTAGE
ACCD75096	dual	208-230/3/60
ACCD75097	dual	480/3/60
ACCD75163	dual	600/3/60

3-fan air-cooled condenser

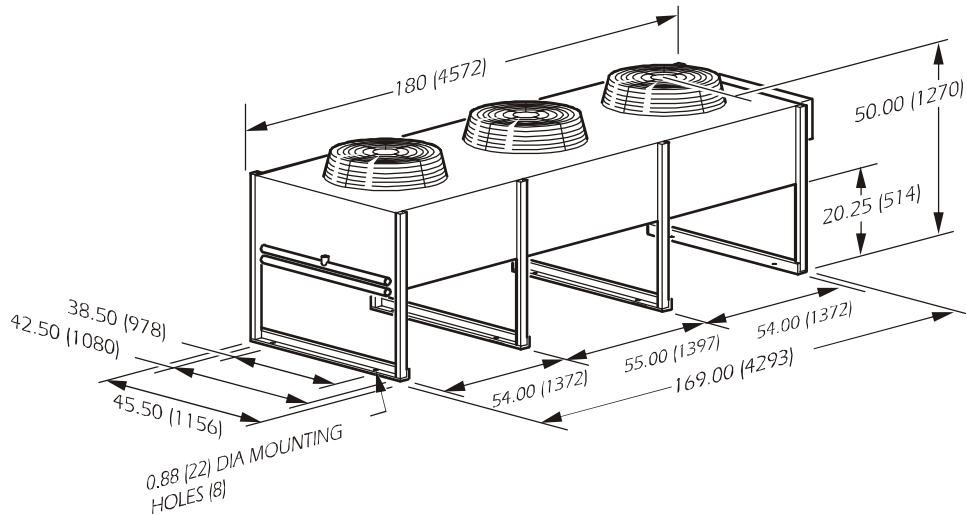

APC PART	CIRCUIT	VOLTAGE
ACCD75100	dual	208-230/3/60
ACCD75101	dual	480/3/60
ACCD75165	dual	600/3/60

Fluid Coolers

Glycol-cooled fluid cooler—performance/electrical data

OHE SKU	Voltage	Ambient Temperature		40% Ethylene Glycol@ 130F	Air Quantity		Feeds	Fan/Motor			Connect-ions	Weight		Glycol Volume		Electrical Data			
		95F	105F		PD(ft)	CFM		L/s	Qty	HP		RPM	Lbs	Kg	Gal	L	FL	MC	MO
		ACFC75116	208-230/3/60		018	018		25.7@20	10,100	4,766		12	2	1/3	1140	(2) 1-3/8	450	204	4.9
ACFC75117	480/3/60	018	018	25.7@20	10,100	4,766	12	2	1/3	1140	(2) 1-3/8	450	204	4.9	18.1	2.6	2.9	15.0	
ACFC75242	600/3/60	018	018	25.7@20	10,100	4,766	12	2	1/3	1140	(2) 1-3/8	450	204	4.9	18.1	2.1	2.4	15.0	
ACFC75144	208-230/3/60	065	N/A	20.7@70	32,900	15,526	21	3	1-1/2	1140	(2) 2-5/8	2360	1070	13.0	49.2	21.0	22.8	25.0	
ACFC75145	480/3/60	065	N/A	20.7@70	32,900	15,526	21	3	1-1/2	1140	(2) 2-5/8	2360	1070	13.0	49.2	10.5	11.4	15.0	
ACFC75251	600/3/60	065	N/A	20.7@70	32,900	15,526	21	3	1-1/2	1140	(2) 2-5/8	2360	1070	13.0	49.2	8.4	9.1	15.0	
ACFC75153	208-230/3/60	N/A	065	16.3@70	43,900	20,716	21	4	1-1/2	1140	(2) 2-5/8	1620	735	16.7	63.2	28.0	29.8	35.0	
ACFC75154	480/3/60	N/A	065	16.3@70	43,900	20,716	21	4	1-1/2	1140	(2) 2-5/8	1620	735	16.7	63.2	14.0	14.9	15.0	
ACFC75254	600/3/60	N/A	065	16.3@70	43,900	20,716	21	4	1-1/2	1140	(2) 2-5/8	1620	735	16.7	63.2	11.2	11.9	15.0	

FLA = Full Load Amps

MCA = Minimum Circuit Amperes

MOP = Maximum Overcurrent Protection

*Fluid coolers can be selected for multiple indoor air conditioning units from the factory. Consult factory for help configuring many-to-one or one-to-many glycol loops.

2-fan fluid cooler

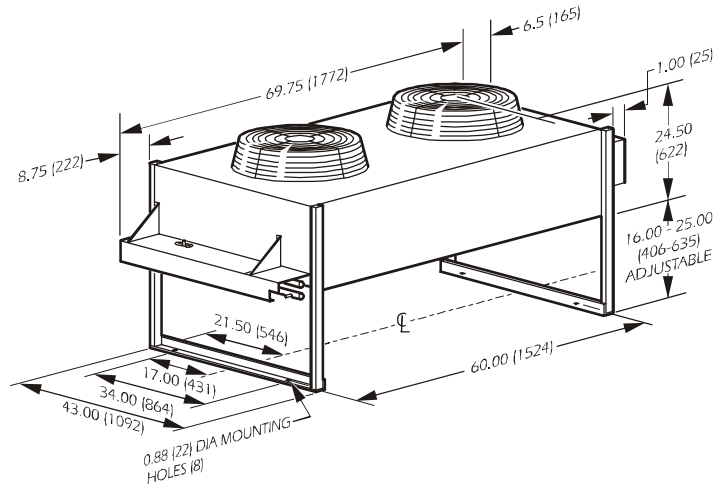

APC PART	VOLTAGE
ACFC75116	208-230/3/60
ACFC75117	480/3/60
ACFC75242	600/3/60

3-fan fluid cooler

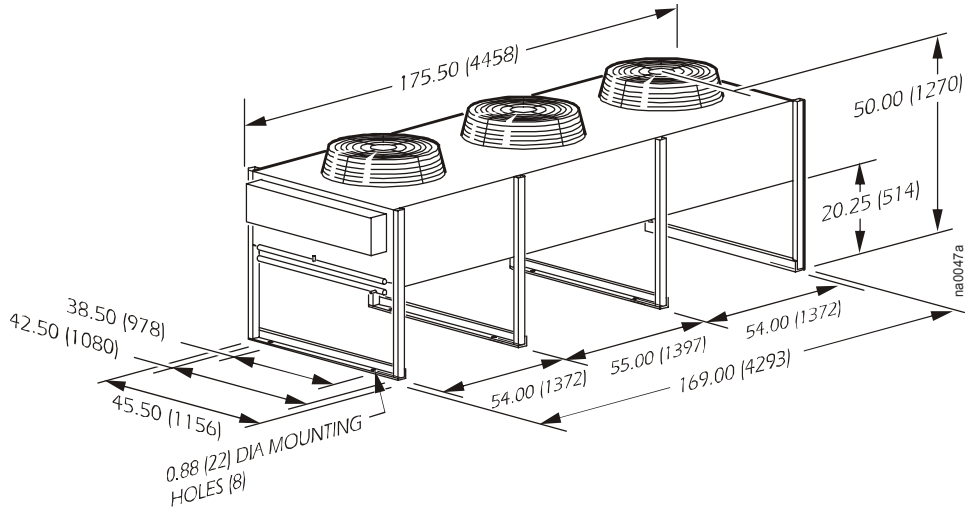

APC PART	VOLTAGE
ACFC75144	208-230/3/60
ACFC75145	480/3/60
ACFC75251	600/3/60

4-fan fluid cooler

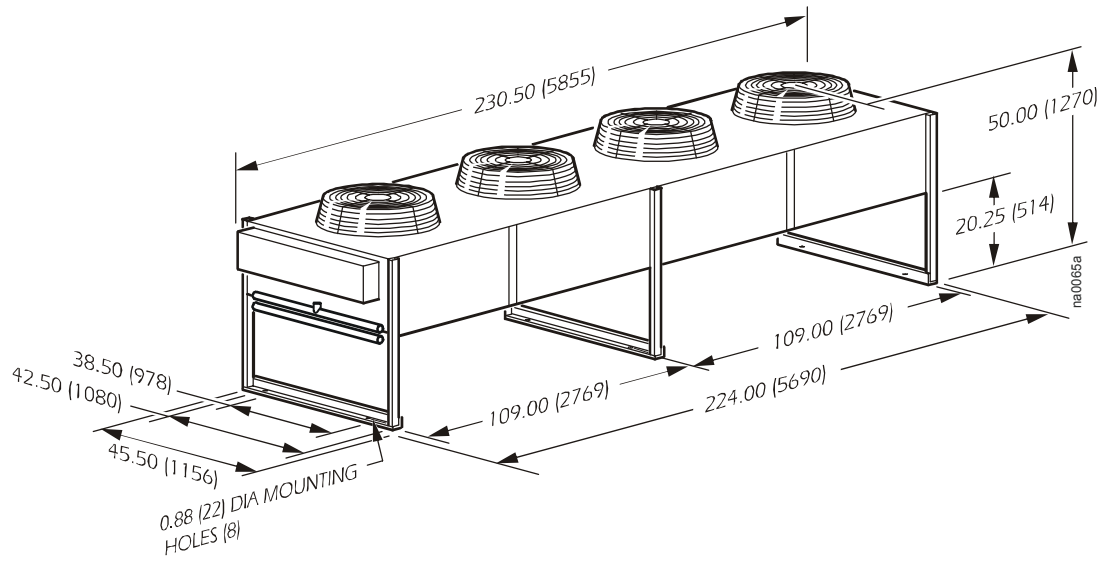

APC PART	VOLTAGE
ACFC75153	208-230/3/60
ACFC75154	480/3/60
ACFC75254	600/3/60

Pump Specifications

Pump performance

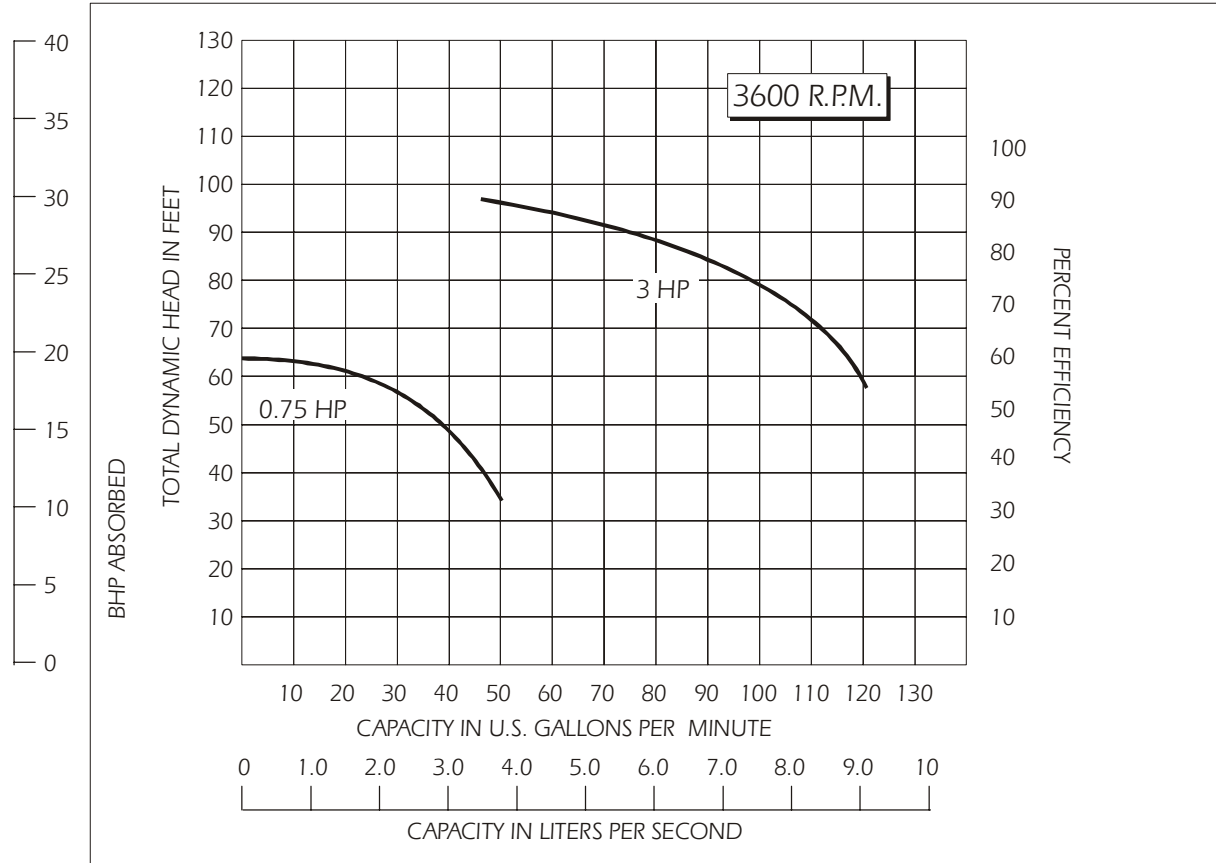

Pump connection sizes

HP (kW)	3/4 (.56)		3 (2.2)	
LINE	Suction	Discharge	Suction	Discharge
Size (inches)	1-1/4	1	2	1-1/2

Pump electrical data

HP (kW)	3/4 (.56)		3 (2.2)	
VOLTAGE	FLA	MCA	FLA	MCA
208-230/3/60	3.5	4.4	8.2	10.3
480/3/60	1.6	2.0	3.8	4.8

*Values are calculated based on 3-phase power.
 FLA = Full Load Amperes
 MCA = Minimum Circuit Amperes

Single Pump Package

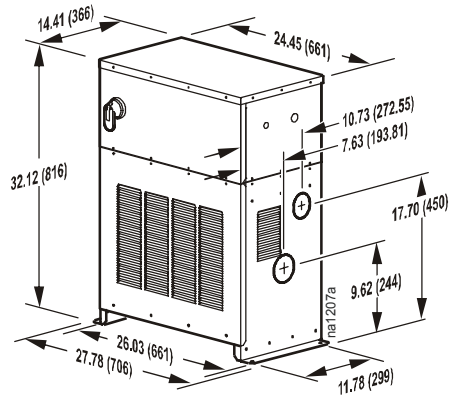

* All dimensions are in inches (mm).

Dual Pump Package

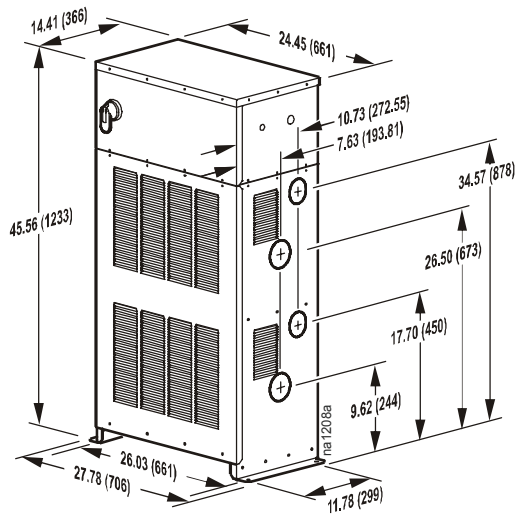

* All dimensions are in inches (mm).

Guide Specifications

PART 1 — PART 1 GENERAL

1.01 SUMMARY

- A. The environmental control system shall be designed specifically for precision temperature and humidity control applications. It will automatically monitor and control heating, cooling, humidifying, dehumidifying, and filtering functions for the conditioned space. The system shall be built to the highest quality engineering and manufacturing standards, and shall be floor mounted and configured for _____ (up/down) discharge of conditioned airflow, with draw-through air pattern, to provide uniform air distribution over the entire face of the coil.

1.02 DESIGN REQUIREMENTS

- A. The system shall be as described in the following specification as manufactured by APC.

1. Model: _____.
2. Total cooling capacity: _____ MBH (kW).
3. Sensible cooling capacity: _____ MBH (kW).
4. Return air temperature: _____ ° F (° C) DB.
5. Return air temperature: _____ ° F (° C) WB.
6. Humidity: _____ % RH.
7. Air quantity: _____ CFM (L/s).
8. External Static Pressure _____ inches (Pa).
9. Humidifier capacity: _____ lbs/hr (kg/hr).
10. Electrical supply: _____ V, _____ ph, 60 Hz.

1.03 SUBMITTALS

- A. Submittals shall be provided with the proposal and shall include: capacity data, electrical data, physical data, electrical connection drawing, and piping connection drawing.

1.04 QUALITY ASSURANCE

- A. The system shall be completely factory-tested prior to shipment. Testing shall include, but not be limited to: complete pressure and leak testing to ensure system integrity, “Hi-Pot” test, and controls calibration and settings. Each system shall ship with a completed test report to verify completion of factory testing procedure. The system shall be NTRL listed, MCA, and electrical system shall be UL Listed to UL 1995 and CSA 22.2 No. 236.

1.05 WARRANTY

- A. System parts shall be warranted for a period of 12months from date of shipment from factory.

PART 2 — PART 2 PRODUCT

2.01 STANDARD COMPONENTS

A. MICROPROCESSOR

1. The microprocessor controller shall provide total environmental control. The system, based on the main controller, shall offer up to eight analog inputs, two analog outputs, twelve digital inputs and thirteen digital outputs. The operator interface shall provide a 4-line, 80-character backlit LCD display. User-friendly menu structure along with clearly defined prompts shall allow the operator to easily move about the program and monitor the following functions and alarm conditions.
 - a. Status: Complete status monitoring shall be provided within the status menu of the microprocessor controller, and shall include the following information: current temperature, current humidity, temperature setpoint, humidity setpoint, cooling status, heating status, humidification status and dehumidification status.
 - b. Alarms: Quick access to any alarm condition shall be facilitated through the menu structure. Presence of a new alarm shall sound an audible alarm. A red alarm LED on the display panel shall remain illuminated until such time that all alarms have been cleared. Alarm annunciation shall include: loss of airflow, clogged filter, high head pressure, low suction pressure, high temperature, low temperature, high humidity, and low humidity. The temperature and humidity alarm setpoints are user adjustable.
 - c. Setpoint: The microprocessor controller shall provide independent setpoints for heating, cooling, humidification, and dehumidification. Automatic setpoint cross-over protection shall prevent the setting of the heat setpoint above the cool setpoint and the humidify setpoint above the dehumidify setpoint. Setpoint adjustment shall be capable of being protected via security code.
 - d. Configuration: Flexibility shall be offered through the use of the configuration menu. It shall closely match the operating requirements by changing the configuration settings. The site configuration shall be stored in the EEPROM and be protected from unauthorized tampering by the user selectable 4-digit security password in the security menu. Configuration options shall include: Fahrenheit or Celsius display, compressor minimum off-time, power-loss restart time-delay, primary-secondary transfer functions, alarm input polarity, alarm enable, temperature deadbands, humidity deadbands, and small room delay.
 - e. Run time: The major components within the unit shall have independent run-timers that monitor and store the accumulated run-hours on the components. The run timers shall be provided with operator-adjustable run-time alarms for proper component maintenance.
 - f. Security: The microprocessor shall have multiple security levels to prevent unauthorized adjustment of the important system parameters. A user-selectable 4-digit password shall allow setpoint and configuration changes.

B. CABINET CONSTRUCTION

1. The cabinet and frame shall be bolt together formed sheet steel. Access panels shall be flush with the frame and insulated with fiberglass 1 in. (25 mm) in thickness, 1.5 lb/ft³ (24.0 kg/m³) in density. The panels shall be powder coated and lift off for access to the unit. A piping and electrical access plate shall be provided in the bottom of the unit. All units shall require front service access, 24 in (610 mm) minimum.

C. FAN/MOTOR SECTION

1. The unit shall be configured for draw-through air pattern, to provide uniform air-flow over the entire face of the coil. The blower shall be double-inlet centrifugal type, with forward-curving blades, dynamically and statically balanced. Each blower shall be independently driven by a high-efficiency motor. The drive package shall be designed for 200% of the fan motor horsepower. Minimum bearing life shall be 200,000 L₁₀ hrs. The motor and blower shall be mounted on a common frame.

D. REFRIGERATION SYSTEM AND COMPRESSOR

1. Each refrigeration system shall consist of a fully protected scroll compressor, evaporator coil mounted over an insulated stainless steel condensate pan, adjustable expansion valve, filter-drier, liquid line solenoid valve, sight glass, receiver, liquid line isolation valve, low pressure switch and manual reset high pressure switch.

E. MAIN POWER DISCONNECT

1. A non-automatic main power circuit breaker shall disconnect all high voltage power to the unit if necessary. The disconnect switch shall be accessible without removing the electric box cover.

F. ELECTRICAL PANEL

1. The electrical system shall conform to National Electrical Code (NEC) requirements. The control voltage shall be 24 VAC, wired in accordance with NEC Class 1 requirements. The wire for the control circuit shall not be smaller than 18-gauge AWG. Each wire shall end with a service loop and be securely fastened by an approved method. Control wires more than 6 in. (150 mm) shall be color-coded or numbered every 3 in. (80 mm) for ease of service tracing. All electrically-actuated components shall be easily accessible from the front of the unit. Each high voltage unit shall be individually protected on all three phases. Main power shall be connected to a circuit breaker mounted on the electrical panel. The compressor and motor shall have overload and short circuit protection. The electrical box shall include all components and controls required for system operation. An emergency cool override manual switch shall be provided with provision for control using a field supplied thermostat. Incoming power is _____ V, _____ phase, 60 Hz.

G. EVAPORATOR COIL/DRAIN PAN

1. The evaporator coil shall use the latest heat-transfer technology, raised lanced-aluminum fins and rifle-bored copper tubes. Coil end-supports shall be galvanized steel. To enhance dehumidification, the coil shall be split into two circuits by a microprocessor-controlled solenoid valve. An insulated stainless steel drain pan for condensate shall be included.

H. AIR FILTER

1. The air filters shall be 30% efficient per ASHRAE Standard 52.1-92, UL Class 2. The full 4" (102 mm) deep, pleated filters shall be replaceable from the front on upflow units and from the top on downflow units.

I. HUMIDIFIER

1. Humidifier shall be self-contained steam-generating type, factory piped and wired, with disposable cylinder and automatic solid-state control circuit. Capacity: _____ lb/h (g/s).

J. ELECTRIC REHEAT

1. Reheat elements shall be low watt density, wired for three-phase, loaded equally on all three phases and shall be electrically and thermally protected by both automatic and manual reset thermal cutouts. Reheat capacity shall be _____ MBH, _____ kW, controlled in _____ (#) steps.

K. CONDENSATE PUMP

1. The Condensate Pump shall be factory installed and wired and shall pump 36 gal/h (0.06 L/s) at 15 ft. (4.6m) head.

L. REDUNDANT GROUP CONTROL

1. Up to six units shall have the ability to communicate with each other to automatically switch upon alarm condition, or time rotation.

M. ENVIRONMENTAL MONITORING UNIT

1. A stand-alone unit shall perform continuous temperature and humidity sensing through two available probes and contact monitoring. Unit shall be controlled by available web, control console, or SNMP interface with network connection. In the event of an environmental anomaly, notification shall be sent to the customer via e-mail or SNMP. The unit shall be 18.25"x 9"x 2.75" (464mm x 229mm x 70mm).

2.02 OPTIONAL COMPONENTS

A. CONDENSER

1. Water and glycol cooled systems shall employ a brazed plate condenser that uses the latest heat transfer technology. Type 316L stainless plates shall be brazed together in a vacuum furnace and shall comply with ASME pressure vessel code. Pressure rating shall be 450 psi (3100 kPa).

B. WATER-REGULATING VALVES

1. Water and glycol cooled systems shall utilize two-way or three-way valves to regulate the amount of water or glycol supplied to the condenser in response to refrigerant discharge pressure. The standard valve pressure rating shall be 150 psi (1030 kPa).

C. DISCHARGE DUCT COLLAR

1. A 1" (25 mm) duct flange shall be provided for field installation on a unit to provide convenient connection to external ductwork.

D. SECONDARY DRAIN PAN

1. Systems shall be provided with two drain pans. The primary stainless steel condensate pan shall lie directly under the cooling coil. The secondary, emergency drain pan shall provide additional protection by catching any water before it reaches the subfloor.

E. SPOT WATER DETECTOR

1. A water detector shall be factory-wired and shipped in the bottom of the unit to sense water and send a signal to the master control giving the operator possible alarm indications options for shutdown. The water detector shall be provided with 15 ft (5 m) of wire.

F. CABLE WATER DETECTOR

1. A leak detection sensing cable shall be shipped loose with the unit. If water or other conductive liquids contact the cable anywhere along its length, the main controller visually and audibly annunciates the leak.
2. The detector shall be provided with 20ft (6 m) of cable. Cable may be cascaded up to 1000ft (300 m).

G. FIRESTAT

1. A firestat shall be factory-installed in the return air to sense heat and send a signal to the main controller shutting down the unit and activating a visual and audible alarm.

H. SMOKE DETECTOR

1. A smoke detector shall be factory-installed in the return air to sense concentrations of smoke and send a signal to the main controller shutting down the unit and activating a visual and audible alarm.

I. REMOTE RELAY SHUTDOWN

1. Remote shutdown of the system can be done by a factory installed relay with a 24V, 120V, or 240V coil. The relay must be powered by others to disable the cooling system.

J. COMPRESSOR LOCKOUT

1. This lockout shall prevent compressor operation in emergency situations where limited back-up power is available.

K. REHEAT/HUMIDITY LOCKOUT

1. When facilities have limited backup power capacity, this lockout shall prevent the operation of electrical loads that are not essential for continued site operation.

L. REMOTE DISPLAY PANEL

1. Facility and building-maintenance personnel shall have the ability to evaluate and control the unit from up to 50ft. from the unit.

M. REMOTE SENSOR(S)

1. Environmental sensor(s) shall be strategically placed, up to 50ft from the unit to better meet the site's cooling needs. The sensor shall be positioned to permit air movement across the sensor.

N. HOT GAS BYPASS

1. Activation of the hot gas bypass circuit shall maintain the evaporator coil temperature during low load conditions.

O. 3-WAY VALVE FLOW SWITCH

1. A Single-Pole, Double-Throw flow switch shall be wired to energize one device and de-energize another device powered from the same source when fluid flow either exceeds or drops below the set flow rate.

P. AIR DEFLECTOR

1. A ninety degree air deflector shall ship loose and shall be _____ in. (mm) high.

Q. FLOORSTAND

1. The heavy gauge floorstand shall raise the unit above the subfloor to match the height of the raised floor. Heights shall be available from 6" (152mm) to 36" (915mm) on upflow units and 12" (305mm) to 36" (915mm) for downflow units, in 3" (76mm) increments and shall be adjustable +/- 1.5". Threaded pedestals shall provide adjustment. Vibration absorbing pads shall be included. Pedestals and vibration pads shall be included. Seismic floorstands shall be available in 12" (305mm), 18" (457mm), and 24" (610mm) heights.

R. PLENUM

1. A discharge plenum shall mount on top of an upflow unit to direct and distribute conditioned air.
 - a. The plenum shall be manually adjustable with double deflecting grilles provided on 3 or 4 sides. Plenum height shall be 20".
 - b. The plenum shall be provided with a duct collar and no grilles. Plenum height shall be 24" (610mm).

S. ENVIRONMENTAL MANAGEMENT SYSTEM

1. A browser-accessible, 1U, rackmountable appliance shall allow monitoring of environmental conditions. Monitoring of one temperature, one humidity, and one vibration sensor shall ship standard. When conditions change, notifications shall be sent via email to the appropriate personnel. The EMS shall provide eight input contacts, 2 output relays, and controllable power outlets for defining actions remotely should conditions warrant it.

T. OHE DISCONNECT

1. A non-fused disconnect switch shall be wired to an outdoor heat exchanger to disconnect high voltage power if necessary.

U. MODBUS/JBUS GATEWAY

1. The Gateway shall translate transmission protocol from the system's network into ModBus/JBus communication protocol. One gateway shall support up to 16 units.

V. DOWNFLOW RETURN DUCT

1. A return duct the length and width of the unit shall be provided for field installation on a downflow unit to provide convenient connection to external ductwork.

W. CUSTOM ALARM DRY CONTACT CLOSURES

1. Each unit shall be equipped with any or all of the listed dry contact closures. Upon activation of the associated alarm, a discreet Normally Open or Normally Closed contact is available for remote monitoring of that discreet alarm.
 - a. High Temperature Alarm
 - b. Low Temperature Alarm
 - c. High Humidity Alarm
 - d. Low Humidity Alarm
 - e. Compressor High Head Pressure Alarm
 - f. Clogged Filter Alarm
 - g. Fire Alarm (with Firestat)
 - h. Smoke Alarm (with Smoke Detector)
 - i. Humidifier Change Canister Alarm
 - j. Water Underfloor Alarm (with Water Detector)
 - k. Condensate Pump Overflow Alarm (with Condensate Pump)
 - l. Loss of Flow (with Flow Switch)

PART 3 — PART 3 INDIVIDUAL SYSTEMS**3.01 AIR-COOLED**

A. The indoor unit shall consist of an evaporator section including evaporator coil, blower package, controls, electrical section, and compressor.

B. CONDENSER

1. Outdoor Propeller Fan Condenser: The outdoor condenser casing shall be made of aluminum, and all structural supports, coil frame, motor drive supports, and mounting legs shall be made of galvanized steel. The condenser shall have copper tubes expanded into aluminum fins. Headers and connections shall be copper. The coil shall be pressure tested and sealed for shipment. The condenser motors shall have permanently lubricated, sealed, ball bearings, and internal overload protection, and operate on _____ V, _____ ph, 60 Hz power. Motors shall be 1140 RPM and mounted inside the condenser casing for weather protection, and shall be wired to a terminal strip in a weatherproof panel on the unit. The direct drive, aluminum fan blade and painted steel hub assembly, shall be protected by a heavy-gauge, vinyl-coated, steel-wire fan guard. On multiple units, each fan section shall be separated by full-width baffles to prevent bypass air. The condenser shall be sized for _____ ° F (°C) ambient, and condensing temperature controls shall be fan speed for -20° F (-29° C) winter ambient. A ship loose pressure relief valve shall ship with the condenser.
2. Flooded Controls: Flooded controls shall maintain head pressure to -30° F (-34.4°C) by regulating the effective condensing area within the condenser coil. Controls shall ship loose and be mounted to the side of the condenser. A ship loose pressure relief valve shall ship with the condenser.

3.02 WATER-COOLED

A. The water-cooled system shall consist of an evaporator section including evaporator coil, blower package, controls, electrical section, compressor, and water-cooled condenser. The condenser shall be stainless steel brazed plate design and shall be controlled by 2-way (3-way optional) head pressure-regulated valve. Maximum water pressure shall be 400 psi (2758 kPa).

3.03 GLYCOL-COOLED

A. The glycol-cooled system shall consist of an evaporator section including evaporator coil, blower package, controls, electrical section, compressor, and glycol-cooled condenser. The condenser shall be stainless steel brazed plate design and shall be controlled by 2-way (3-way optional) head pressure-regulated valve. Maximum water pressure shall be 400 psi (2758 kPa).

B. FLUID COOLER

1. Outdoor Fluid Cooler: The fluid cooler casing shall be of aluminum, and all structural supports, coil frame, motor-drive supports, and mounting legs shall be made of galvanized steel. The fluid cooler coil shall have copper tubes expanded into aluminum fins. Headers and connections shall be copper. The coil shall be pressure-tested and sealed for shipment. The fluid cooler motors shall have permanently lubricated, sealed, ball bearings, and internal overload protection. Motors shall be mounted inside the fluid cooler casing for weather protection and wired to a terminal strip in a weatherproof panel on the unit. The direct-drive, aluminum fin blade and painted steel hub assembly shall be protected by a heavy-gauge, vinyl-coated, steel-wire fan guard. On multiple fan units, each fan section shall be separated by full-width baffles to prevent bypass air. The Fluid Cooler shall be sized for 95° F (35° C) ambient, and operate on _____ V, _____ ph, 60 Hz power.

C. PUMP PACKAGE

1. Single Pump Package: The pump package shall be comprised of a centrifugal pump in a vented enclosure with pump starter, separate Fluid Cooler fan and pump circuit breakers, Aquastat, and fan cycling contractors to control the fluid temperature. The controls shall be mounted in a weather-tight box. A _____ gal (L) expansion tank and Airtrol fitting shall be supplied for field installation. The pump size shall be sized for _____ GPM (L/s) at _____ ft (m) external head, and operate on _____ V, _____ ph, 60 Hz power.
2. Dual Pump Package: The dual pump package shall consist of two centrifugal pumps in an enclosure. Pump starters, automatic pump switch-over controls, lead-lag pump selector switch, separate Fluid Cooler fan and pump circuit breakers, Aquastat, and fan cycling contractor to control the fluid temperature shall be mounted in a separate weather-tight box. A _____ gal (L) expansion tank and Airtrol fitting shall be supplied for field installation. Each pump shall be sized for _____ GPM (L/s) at _____ ft (m) external head, and operate on _____ V, _____ ph, 60 Hz power.

Guidelines for Installation

The AFX provides reliable, accurate temperature and humidity control of computer rooms, laboratories, and other environments that require close tolerance control. The unit incorporates the latest system design innovations to provide you with optimum efficiency, reliability, and accuracy of control.

The AFX system will provide years of trouble-free service, when installed and maintained by technically qualified personnel.

Room preparation

During the design of the room, consideration should be given to the following factors: ease of entry for the system, floor-loading factors, and accessibility of piping and wiring.

The room must be sealed with a vapor barrier to minimize migration of moisture. Polyethylene film (plastic sheeting) is a good vapor barrier for ceiling and wall applications. Rubber- or plastic-based paints should be applied to concrete floors and walls. The room should be thoroughly insulated to minimize thermal loads and make-up air (if required) should be preconditioned to reduce additional temperature, filtration, and moisture loads.

A room using a raised-floor plenum for air distribution should have at least 9" (300 mm) of clear space between the false floor and sub-floor for a finished floor height of 12" (380 mm). Pay special attention to the location of pipe chases, electrical conduits and other obstructions under the floor. These objects can block air circulation and cause loss of air pressure, thus reducing system efficiency and causing hot spots in your room.

Minimum clear space of 18" (460 mm) is to be provided for units over 15 tons (53 kW).

APC should be notified before installation if the unit is incorrect for the application.

Unit location

The location of the unit is important for efficient and balanced environmental control in your room. The air conditioner should be located as close as possible to the largest heat load. In rooms having a high aspect ratio, mount the unit along the longest wall to ensure even air distribution. If improperly installed, erratic control or mechanical failure can and will result.

- Service access** At least 24" (610 mm) of clear space must be left in front of the unit for routine service (filters, humidifier). We strongly recommend approximately 32" (813 mm) clearance in front of the unit.
- Receiving the unit** Your AFX unit has been completely tested and inspected prior to shipment. To ensure that you have received the unit in excellent condition, perform a careful inspection of the crating and the unit immediately upon receipt. Verify that all parts ordered were received as specified and that the unit is the correct size and voltage necessary to fulfill your environmental control needs. Report any damage discovered to the freight carrier. If necessary, contact the APC field service department for help in repairing or replacing damaged parts. While APC is not responsible for damage incurred in transit, we want to make sure that you have no undue delays in your system start-up.
- Rigging** The unit is manufactured with a formed steel frame for maximum strength and unit integrity. However, as with all electrical and mechanical equipment, you must take care with proper rigging of your unit.
- When using a forklift to move the unit, use the shipping skid to protect the bottom of the unit. When using chains, cables or rope to lift the unit, use spreader bars to prevent damage to the finished panel.
- Floorstand** Install a threaded pedestal into each leg of the floorstand. Use the washer and nut on each panel to tighten against the floorstand leg.
- Utility connections** All connections are made through the bottom left of the unit (the left side of upflow discharge units) for ease of service connections. Refer to the installation manual for pipe sizes and specific locations for your unit.
- Power unit** The AFX unit uses 3-phase power for operation. Power connections are landed to a receptacle on either floorstand or sub base. Bring the service cable through the bottom left of the unit and through the bulkhead hole into the electrical box to the circuit breaker provided on the left side of the electrical box. The ground lug is located near the 3-phase high-voltage connector. **THE UNIT MUST BE UTILITY GROUNDED OR THE WARRANTY IS VOID.**
- Humidifier connections** The humidifier inlet connection point is provided with the equipment. A 1/4" (6.4mm) compression connection is supplied with the unit.
- Condensate drain** Condensate from the evaporator pan is collected and discharged by the condensate pump to a 7/8" (22.2mm) fitting for field connection.

Water supply to humidifier

1. The humidifier fill valve orifice is sized for supply water pressure from 15 PSIG (103.4 kPa) to 150 PSIG (1034 kPa).
2. For cases above 150 PSIG (1034 kPa), install a pressure-reducing valve in the water feed line to the unit.
3. With extremely dirty or muddy water sources, proper filtration is required on the unit's incoming water line.
4. DO NOT use softened water with the humidifier. Softened water is too conductive.
5. DO NOT use completely demineralized water with the humidifier. The minerals allow the electrode principle to work.
6. DO NOT use a hot water source. Doing so will cause deposits that will eventually block the fill valve orifices.
7. Water supplies with high conductivity (above 800 mW) must be preconditioned for proper operation and longevity of the humidifier.

Water supply

A 16- to 20-mesh strainer must be installed in the water supply to the water units to prevent clogging of brazed plate condenser. This is a field item. Also recommended on glycol units.

Note: Because of an ongoing program dedicated to product improvement, specifications are subject to revisions without notice. APC assumes no responsibility, and disclaims all liability for damages resulting from use of this information or for any errors or omissions.



APC Worldwide Customer Support

Customer support for this or any other APC product is available at no charge in any of the following ways:

- Visit the APC Web site to find answers to frequently asked questions (FAQs), to access documents in the APC Knowledge Base, and to submit customer support requests.
 - **www.apc.com** (Corporate Headquarters)
Connect to localized APC Web sites for specific countries, each of which provides customer support information.
 - **www.apc.com/support/**
Global support with FAQs, knowledge base, and e-support.
- Contact an APC Customer Support center by telephone or e-mail.
 - Regional centers:

APC headquarters U.S., Canada	(1)(800)800-4272 (toll free)
Latin America	(1)(401)789-5735 (USA)
Europe, Middle East, Africa	(353)(91)702020 (Ireland)
Asia Pacific	(61) 2 9955 9366 (Australia)

- Local, country-specific centers: go to **www.apc.com/support/contact** for contact information.

Contact the APC representative or other distributor from whom you purchased your APC product for information on how to obtain local customer support.

Entire contents copyright © 2005 American Power Conversion. All rights reserved. Reproduction in whole or in part without permission is prohibited. APC, the APC logo, and NetworkAIR are trademarks of American Power Conversion Corporation and may be registered in some jurisdictions. All other trademarks, product names, and corporate names are the property of their respective owners and are used for informational purposes only.